

THINK ELECTRICAL

INDUSTRIAL SWITCHGEAR

SHORTFORM CATALOGUE '18



PREVIEW OF THE NEW '18|19 MAIN CATALOGUE



NATIONAL CONTACT CENTRE

Sales Centre 010 202 3400
Technical 010 202 3500

BRANCH CONTACT DETAILS

Johannesburg 010 202 3300
Germiston 011 418 9600
Cape Town 021 510 0710
Pinetown 031 700 4215
Riverhorse 031 492 4800

Leaders in motor control.
Suppliers of electrical equipment for
distribution, control & protection.

ELECTRIC MOTOR / PUMP PROTECTION RELAYS



TE01



TE02/TE03

M1

Pump and Motor Protection / Phase Angle Relays

Specifications

Supply Voltage	230VAC ±20% Single phase 400VAC or 525VAC ±20% 3 phase 415VAC ±20% 3 phase (TE02/TE03)
Power Consumption	2VA
Calibration	Manual or Automatic (Model dependant)
Dry Trip Level	10% of calibrated phase angle / current 2s delay
Dry Restart Delay	15 minutes to 5 hours adjustable
Output Relay	SPDT 250VAC/10A
Voltage Trip Level	10% of calibrated voltage, 2 sec delay (TE02/TE03)
Current Trip Level	20% of calibrated current, 1 sec delay (TE02/TE03)
Rapid Start Cycle	3 per 15 minutes maximum (TE03 only)

LED Status Indication TE02/TE03

Green	Amber	Red	Condition
ON	OFF	OFF	Normal Pumping
FLASH	OFF	OFF	Dry-timing or phase failure/reversal
OFF	ON	OFF	Supply Voltage Low/High
OFF	FLASH	OFF	Rapid Cycle
OFF	OFF	ON	Motor Overload or Phase Failure
ON	ON	ON	TE02/3 Uncalibrated
FLASH	FLASH	FLASH	TE02/3 Calibrating
OFF	OFF	OFF	Unable to Calibrate

Selection Guide

Code	TE01*	TE02*	TE03*
11 Pin Plug In	•	•	•
Running dry- Under load blocked in/outlet	•	•	•
Overcurrent		Auto	Auto
Phase Failure / Reversal		•	•
Over / Under voltage		•	•
Star/Delta or Soft Start	•**	•	•
Locked Rotor		•	•
Shunt Required	•		
Rapid pump start protection			
Cut-out over 12 starts/hour			•
LED Status Indication			•
Calibration	Manual	Auto	Auto
Tank Control (float switch)			•

*Add to Code: 230V (230VAC), 400V (400VAC), 415V (415VAC), 525V (525VAC) **TE01/S version only

Accessories

Code	Description
TE01 SHUNT R	Spare Red Shunt
TE01 SHUNT W	Spare White Shunt

Current Transformer Selection Chart for TE Series

TE01	230VAC				400VAC											
	-	PW155	PW205	PW255	-	-	PW205	PW305	PW405	PW405	DS-505	DS-755	DS-1005	DS-1005	DS-1055	
TE02/03	-	PW155	PW205	PW255	-	PW155	PW205	PW305	PW405	PW405	DS-505	DS-755	DS-1005	DS-1005	DS-1055	
HP	0.36-1.1	1.5	2	3	0.5-1.5	2-7.5	10	15	20	25	30	40	50	60	75	
Kw	0.25-0.75	1.1	1.5	2.2	0.37-1.1	1.5-5.5	7.5	11	15	18.5	22	30	37	45	55	
Shunt	White				Red		White									

ELECTRONIC MOTOR & OVERLOAD PROTECTION RELAYS



Phase Angle Motor Protection Relays

Mainly used for borehole protection with liquid level control tank filling. DIN mount.



Code	Description	Max. Current Continuous
MP820/230VAC-SP	Single phase motor protection relay up to 1.1kW	* 15A
MP825/230VAC-SP	Single phase motor protection relay above 1.1kW	* 15A
MP830/230VAC-SP	Three phase motor protection relay up to 3.7kW	* 12A
MP830/400VAC-SP	Three phase motor protection relay up to 3.7kW	* 12A
MP830/525VAC-SP	Three phase motor protection relay up to 3.7kW	* 12A
MP835/230VAC-SP	Three phase motor protection relay up to 3.7kW	* 12A
MP835/400VAC-SP	Three phase motor protection relay up to 3.7kW	* 12A

* For higher load current use 5 Amp CT to achieve accurate calibration

Single Phase Features

- MP820:**
- Direct in-line current sensing of motor, up to 1.1kW
 - Auto calibration of over/under current and voltage
 - Start up delay (3 seconds standard)
 - Adjustable reset time 15 mins to 24 hrs
 - Latching on overload conditions
 - Liquid Level Control (50kΩ)
 - Reset Lock out, Max 3 reset attempts in 15 minutes
- MP825:** As for MP820 plus
- Latching of over and under load conditions
 - Manual adjustment of under load sensitivity (after auto calibration)

Three Phase Features

- MP830:**
- Direct in-line current sensing of motor, up to 3.7kW
 - Auto calibration of over/under current and voltage
 - Start up delay (3 seconds standard)
 - Adjustable reset time 15 mins to 24 hrs
 - Latching of over load conditions
 - Liquid Level Control (50kΩ)
 - Reset Lock out, Max 3 reset attempts in 15 minutes
 - Phase sequence/phase failure detection
- MP835:** As for MP830 plus
- Latching of over and under load conditions
 - Manual adjustment of under load sensitivity (after auto calibration)

ELECTRIC MOTOR / PUMP PROTECTION RELAYS

Motorscope Pump Protection Relay - Protection of AC motors and their driven systems can be achieved by limiting the maximum and minimum consumed motor power. The power consumption (kW) formula is: $P = \sqrt{3} \times V \times I \times \text{Cos}\phi$. All Motorscopes mount directly onto DIN RAIL.

Features	UNO	TRIO	SUPRA	^{NEW} SUPRA MOBI	SUPRA 5 (525V)	B110*
Description	1 Phase 230V 0.37-2.2kW	3 Phase 400V 0.37-5.6kW	3 Phase 400V 5.6-37kW	3 Phase 400V 7.5-37kW	3 Phase 110V Control 7.5-45kW	Industrial 110/230 400/525 1000V
Running dry, under load blocked inlet/outlet	●	●	●	●	●	●
Overcurrent	●	●	●	●	●	●
Phase failure/phase reversal	—	●	●	●	●	●
Phase imbalance	—	●	●	●	●	●
Over / Under voltage	●	●	●	●	●	●
Star Delta and Soft start connection	—	●	●	●	●	●
Tank control (float/pressure switch)5VDC	●	●	●	●	●	●
Locked rotor	●	●	●	●	●	●
CT250/1 Supplied with unit	●	—	●	●	●	●
Built-In Optimizer	—	—	●	MOBI	●	—

LED Status Indication			
Green	Amber	Red	Condition
ON	OFF	OFF	Normal Running
OFF	FLASH	FLASH	Voltage Fault
OFF	FLASH	OFF	Underload/ Restart
OFF	FLASH	ON	Current Fault
FLASH	FLASH	OFF	Start Delay
OFF	ON	ON	Phase Rotation Fault
OFF	OFF	ON	Overload
OFF	ON	OFF	Underload



B110: * To be used where the supply voltage and the motor voltage differ, e.g. Motor is 1000V and the control is 110V. Note: Specify motor/control voltage when ordering.

DOWNLOADER

OPTIMIZER

AGEM

MOBI

Accessories

Code	Description
DOWNLOADER	Comprises of PC software and hardware to download data from Motorscope to PC. It can also interface between Motorscope and PC for data logging and real time graphic display of parameters. Supplied with cables.
OPTIMIZER	Has 2 functions: 1) For commissioning, it can modify a number of factory default settings to optimise the Motorscope for each application, as well as viewing every operational parameter. 2) For maintenance, it can download the last 30 events from the Motorscope and in turn download data to a PC via DOWNLOADER .
AGEM	Advanced GSM Enabled Modem which acts as a gateway between Motorscope relay and the internet. Data is transferred from the device to an online database. The data stored on the database can then be accessed through our browser based ROCS (Remote Online Control System)
MOBI	Mobi is an optional addition (PCB) to any of the motorscope units and provides bluetooth communication to a smart phone. MOBI can replace and provide the same services as the OPTIMIZER and DOWNLOADER . MOBI shows current motor status, live motor starts, Limits and trip graphs Information downloaded to the smart phone can be transferred to a PC as PDF files



Electronic Overload Protection Relays

Code	Current Range	OL	PL	LR	PU	PR	STL	UL	ALT	GF	Trip Type	Disp Type	Control Voltage
CSMPA-60-T 6A	0.5-6A	●	●	-	-	-	-	-	-	-	D	LED	230VAC
CSMPA-60-T 60A	5-60A	●	●	-	-	-	-	-	-	-	D	LED	230VAC
CSMPA-22-3S-5A0	0.3-1.5A	●	●	-	●	-	●	-	-	-	I	LED	230VAC
CSMPA-22-3S5A	1-5A*	●	●	-	●	-	●	-	-	-	I	LED	230VAC
CSMPA-40R 1-SA	0.3-1.5A	●	●	-	●	●	●	-	-	-	I	LED	230VAC
CSMPA-40R 5A	1-5A*	●	●	-	●	●	●	-	-	-	I	LED	230VAC
CSMPM-06-SZ	0.5-6A	●	●	●	●	●	●	●	●	●	I + D	LED	230VAC
CSMPM-60-SZ	5-60A	●	●	●	●	●	●	●	●	●	I + D	LED	230VAC

Key: OL: over current PL: Phase Loss LR: Locked Rotor PU: Phase Unbalance PR: Phase Reverse
 STL: Stalling UL: Under Current ALT: Alert (60-110%) GF: Ground Fault I: Inverse Time
 D: Definite Time ●: Available -: not available LED: Red & Green SSD: Seven Segment Display

Accessories

Code	Description
CSMPM - 1.5M	1.5m ext cable for CSMPM - 06/60-SZ
CSMPM - 4M	4m ext cable for CSMPM - 06/60-SZ

*NOTES: CSMPA22 - models with current range 1 - 5A can be used up to 600A with suitable ratios CTs having 5A secondary, class 1 accuracy.

Ground Fault Core Balance Transformer

Code	Hole Ø
Z-CT D30	30mm
Z-CT D50	50mm
Z-CT D65	65mm
Z-CT D80	80mm

ELECTRONIC MOTOR PROTECTION RELAYS



LA-Series

Current Range	Code Standard	Code with Battery ⁽¹⁾
1-10A	LA-010	LA-010N
5-50A	LA-050	LA-050N
10-100A	LA-100	LA-100N
25-250A	LA-250	LA-250N

(1) Required to maintain LED status if within cubicle with electrical interlock

Features - See chart on pg 171 for protection

- Overload protection cyclic and sustained based on a 15 second cold curve
- Integrated current transformers
- 1NO + 1NC 6A@250VAC
- 110/220VAC control supply

KA-



KB-



KC-



K-Series

Current Range	Code KA	Code KB	Code KC	CT's Required
0.1-1A	KA-001	KB-001	KC-001	-
0.5-5A	KA-005	KB-005	KC-005	-
1-10A	KA-010	KB-010	KC-010	-
2.5-25A	KA-025	KB-025	KC-025	-
5-50A	KA-050	KB-050	KC-050	-
10-100A	KA-100	KB-100	KC-100	100:5
20-200A	KA-200	KB-200	KC-200	200:5

Features See chart on pg 171 for protection

- Overload protection cyclic and sustained based on a 15 second cold thermal curve
- KA is powered from the 3ph 400V or 525V mains supply
- KB & KC is suitable for 110V/220VAC control only
- 1NO + 1NC 6A@250VAC

For CTs see page XXXX

MA-250-PM



MA-RDU-1



MA-RDU216



MA-Series

Description	Current Range	Code
Relay Without fieldbus interface	0.5-5A	MA-005-*
	1-10A	MA-010-*
	5-50A	MA-050-*
	10-100A	MA-100-*
	25-250A	MA-250-*

For larger currents, use MA-005 with 3 x 5A CL1 CTs

Profibus comms replace * with	*...-PM
Modbus comms replace * with	*...-MM
Canbus comms replace * with	*...-CM
Laptop Cable 1m	MA-CAB1
CD Front End Software	MA-CD
Door mount fault indicator c/w 1.5m cable	MA-RDU-1
Door mountable MMI programming & interface unit c/w 1m cable	MA-RDU216
Security Dongle for MA-RDU216	MA-SD

Features See chart for "full house" protection info.

- Overload protection cyclic and sustained with user adjustable thermal curves 5 to 35 seconds
- Field bus interfaces
- Software programmable LV protection for process control
- 5 x programmable digital inputs
- 4 x 1C/O relay outputs 5A@220VAC
- 110V/220VAC control supply

To set up or alter parameters, either use laptop with software (free) and cable, or MA-RDU216 (supplied with 1.5m cable and security dongle)

ELECTRONIC MOTOR PROTECTION RELAYS

KD-



KE-* with profibus BBRTU module



KD-MMI420-EP



KD-FLED



KD-RDU420

Features

- Stores 2000 events and 60 faults with time and date stamping
- Thermal curves selectable
- Profibus communication
- Earth leakage with harmonics filtering ideally suited for V.S.D. and large D.O.L applications
- KE-Relay does power measurement, real and apparent, in real time or consumption over time

KD-Series - Supply Volts 110/230VAC

Current Range	Code KD	Code KE	CT's Required
0.5-5A	KD-005	KE-005	Internal
1-10A	KD-010	KE-010	Internal
2.5-25A	KD-025	KE-025	Internal
5-50A	KD-050	KE-050	Internal
10-100A	KD-100	KE-100	100:5 Class 1 2.5VA
25-200A	KD-200	KE-200	200:5 Class 1 2.5VA
40-400A	KD-400	KE-400	400:5 Class 1 2.5VA

Note: KE-Relay cannot be programmed via front panel

Accessories

Code	Description
KD-FLED	Door mount indicator with Reset, Test and last fault indication. Provides IR link to MMI or Laptop
KD-RDU420	Door mount Paramatrization unit to set KD-KE parameters and display values and faults. Provides IR link to MMI or Laptop.
KD-MMI420-EP	To set KD-KE parameters, upload events, upload fault records, display actual values and faults, connects via IRDA to relay
FPR0768	KD-KE profibus BBRTU module for profibus communication
CAB0100	RJ11-RJ11: Cable for connecting KD-FLED/KD-RDU420 to relay
CAB0101	RJ11-RS232: Cable for connection between relay and computer
CAB0016	USB to serial converter
FPR0202	RJ11-IRDA: Infrared eye for relay
FPR0205	RS232-IRDA: Infrared eye for computer

Protection Features

- Overload (both cyclic and sustained overload)
- Locked rotor by vectorial stall
- Running stall/jam
- Single phasing/unbalance
- Over/Under frequency protection
- Insulation failure prestart lock-out
- Undercurrent/load loss/cavitation
- Under power (CosØ measurement)
- Phase rotation/over or under voltage
- Short circuit protection trip threshold power factor dependant
- Starts per hour with selectable 1-3 consecutive start attempts

Protection Features for Newelec Relays

	LA	KB	KA	KC	MA*	KD/KE		LA	KB	KA	KC	MA*	KD/KE
Max. current (w/o ext. CTs)	250A	50A	50A	50A	250A	50A	Max. current (w/o ext. CTs)	250A	50A	50A	50A	250A	50A
Thermal memory	✓	✓	✓	✓	✓	✓	Under voltage			✓	✓	✓	✓
Locked rotor (at start)	✓	✓	✓	✓	✓	✓	Voltage phase symmetry			✓	✓	✓	✓
Jam (from running)				✓	✓	✓	LED trip indication	✓	✓	✓	✓	✓	✓
Unbalanced load	✓	✓	✓	✓	✓	✓	Door mount control option					✓	✓
Phase loss	✓	✓	✓	✓	✓	✓	MCCB fail - upstream tripping					✓	
User select O/L auto reset		✓	✓	✓(1)	✓(1)	✓(1)	MCCB/Contactor co-ordination					✓	
Under current		✓	✓	✓	✓	✓	Earth leakage* (core incl. up to 250A)					✓	✓
Restart timer				✓	✓	✓	Protocol option					✓	
Restart contact				✓	✓	✓	3 x PTC100 inputs					✓	
Phase rotation			✓	✓	✓	✓	Totalised running hours					✓	
Over voltage			✓	✓	✓	✓	Last 4 faults memory					✓	

* For MA, CB CT is internal up to 250A. For over 250A use external core balance CT, see page 172. (1) 3 Starts per hour limit in auto mode.

ELECTRONIC MOTOR PROTECTION RELAYS

Comprehensive Motor Protection & Control Relay - Size: 99(H) x 45(W) x 113(D)mm



Code	FPR0400
Supply Voltage	110 - 230VAC/DC
Power Usage	2.5W
Relay Outputs	4 x C/O (5A@220VAC)
3 Phase Current Measurement	1 - 400A
Voltage Range	110 - 1100V (Via CT Module Block / Volt Converter)
Earth Leakage	30mA - 3A
Insulation Resistance Measurement	1-99kΩ
Real Time Clock	24 Hours
Battery Back-up for Clock	5 Days

- Fully configurable with the aid of free software or Man Machine Interface (MMI)
- Two types of Date/Time based records are stored in the onboard database store:
 - A. Fault Records (last 35 faults)
 - B. Event records (1400 events)
- Event records can be downloaded for further analysis
- All settings can be password protected
- A spectrum analyser for analysis of power quality and harmonics (up to 9th)
- Supported Comms Protocols: Profibus, Modbus, Canbus

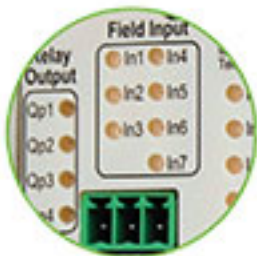

LED Indication of Input/Output State



LED Fault Indication



IRDA & USB Communication & Profibus address indication.



Configurable Memory Module on a T-Bus (option) allows easy replacement & setup.

Protection Features

- Thermal Overload
- Locked Rotor
- Running Stall-Jam
- Vectorial Start - Start Stall
- Unbalanced Current
- Single Phasing
- Underload - Dry Run
- Earth Fault / Leakage
- Short Circuit
- Starts per Hour Limitation
- Over/Under Voltage
- Phase Rotation
- Over/Under Frequency
- Insulation Lock-Out

Automation Features

- Timers
- Real Time Clock
- Start Control Logic
- Logic Function Blocks
- 7 Field Inputs
- Motor Parameter Calculator
- 4 Programmable Outputs
- 3 Phase Recorder
- Multiple Comms Protocols
- On Board Simulator for Training / Commissioning

Management Features

- Power Factor Measurement
- Power Consumption Measurement
- 35 Last Fault Records
- Statistical Data
- 1400 Event Records

Accessories



FPR0401/2

FPR0407



FPR0412



FPR0413



FPR0414



BTX0005



FPR0420



FPR0404/5/6



FPR0409

Code	Description
FPR0407	External settings Memory Module for easy maintenance
FPR0420	Insulation Lock Out - Monitors resistance of static motor prevents start up if below 20kΩ
FPR0412	Expansion I/O, 8 In/4 Out (programmable relays)
FPR0413	RTD expansion module - 4 inputs which can be NTC, PTC, PT100 or PT1000
FPR0414	4/20mA module - 2 x input loops and 2 x output loops
FPR0404	CT Module Block 0.5 - 5A / 110 - 550VAC Volt Converter
FPR0405	CT Module Block 2.5 - 25A / 110 - 550VAC Volt Converter
FPR0406	CT Module Block 5 - 50A / 110 - 550VAC Volt Converter
FPR0402	CT Module Block 10 - 100A / 110 - 550VAC Volt Converter
FPR0401	CT Module Block 30 - 300A / 110 - 550VAC Volt Converter
FPR0208	Volt Converter - 1100V to 550V
FPR0408	CT Module to Relay Cable 1m
FPR0409	CT Module to Relay Cable 500mm
FPR0410	CT Module to Relay Cable 300mm
FPR0411	CT Module to Relay Cable 100mm
BTX0004	Core Balance CT 43mm
BTX0001	Core Balance CT 60mm
BTX0002	Core Balance CT 100mm

BOREHOLE PUMP CONTROLS



DOL Borehole Pump Control Panels with TE03 Pump Protection Relay

Protection Features: Dry run, locked rotor, overload, phase failure/reverse/imbalance, over/under voltage, LED Status indication through window. Auto calibration for ease of commissioning.

General Features: Supplied with an Isolator, Contactor or Soft Starter, CT (where required), Lightning Arrestors, TE03 protection relay, "Power On" and "Pump Run" LED indication lights.

Control Options: Standard: Hand / Off / Auto Selector Switch / Float Switch
 LL: Hand / Off / Auto Selector Switch / Liquid Level Relay
 U: Hand / Off / Auto Selector / 24-hour Timer

For optional extras, see below.



Pump kW	Polycarbonate Enclosure IP56			Metal Enclosure IP65		
	Float Switch*	With Liquid Level*	With Time Switch	Float Switch*	With Liquid Level*	With Time Switch

Single Phase 230VAC DOL

0.75kW	B00S/IS/P U	B00S/IS/LL/P U	B00S/IS/U/P U	B00S/IS/S U	B00S/IS/LL/S U	B00S/IS/U/S U
1.1kW	B09S/IS/P U	B09S/IS/LL/P U	B09S/IS/U/P U	B09S/IS/S U	B09S/IS/LL/S U	B09S/IS/U/S U
1.5kW	B12S/IS/P U	B12S/IS/LL/P U	B12S/IS/U/P U	B12S/IS/S U	B12S/IS/LL/S U	B12S/IS/U/S U
2.2kW	B18S/IS/P U	B18S/IS/LL/P U	B18S/IS/U/P U	B18S/IS/S U	B18S/IS/LL/S U	B18S/IS/U/S U

Three Phase 400VAC DOL

4kW	B09T/IS/P N	B09T/IS/LL/P N	B09T/IS/U/P N	B09T/IS/S N	B09T/IS/LL/S N	B09T/IS/U/S N
5.5kW	B12T/IS/P N	B12T/IS/LL/P N	B12T/IS/U/P N	B12T/IS/S N	B12T/IS/LL/S N	B12T/IS/U/S N
7.5kW	B18T/IS/P N	B18T/IS/LL/P N	B18T/IS/U/P N	B18T/IS/S N	B18T/IS/LL/S N	B18T/IS/U/S N
11kW	B25T/IS/P N	B25T/IS/LL/P N	B25T/IS/U/P N	B25T/IS/S N	B25T/IS/LL/S N	B25T/IS/U/S N
15kW	B32T/IS/P N	B32T/IS/LL/P N	B32T/IS/U/P N	B32T/IS/S N	B32T/IS/LL/S N	B32T/IS/U/S N
18.5kW	B40T/IS/P N	B40T/IS/LL/P N	B40T/IS/U/P N	B40T/IS/S N	B40T/IS/LL/S N	B40T/IS/U/S N
22kW	B50T/IS/P N	B50T/IS/LL/P N	B50T/IS/U/P N	B50T/IS/S N	B50T/IS/LL/S N	B50T/IS/U/S N
30kW	B65T/IS/P N	B65T/IS/LL/P N	B65T/IS/U/P N	B65T/IS/S N	B65T/IS/LL/S N	B65T/IS/U/S N

Three Phase 400VAC Soft Start

5.5kW	BS05T/IS/P N	BS05T/IS/LL/P N	BS05T/IS/U/P N	BS05T/IS/S N	BS05T/IS/LL/S N	BS05T/IS/U/S N
7.5kW	BS07T/IS/P N	BS07T/IS/LL/P N	BS07T/IS/U/P N	BS07T/IS/S N	BS07T/IS/LL/S N	BS07T/IS/U/S N
11kW	BS11T/IS/P N	BS11T/IS/LL/P N	BS11T/IS/U/P N	BS11T/IS/S N	BS11T/IS/LL/S N	BS11T/IS/U/S N
15kW	BS15T/IS/P N	BS15T/IS/LL/P N	BS15T/IS/U/P N	BS15T/IS/S N	BS15T/IS/LL/S N	BS15T/IS/U/S N
18.5kW	BS18T/IS/P N	BS18T/IS/LL/P N	BS18T/IS/U/P N	BS18T/IS/S N	BS18T/IS/LL/S N	BS18T/IS/U/S N
22kW	BS22T/IS/P N	BS22T/IS/LL/P N	BS22T/IS/U/P N	BS22T/IS/S N	BS22T/IS/LL/S N	BS22T/IS/U/S N
30kW	BS30T/IS/P N	BS30T/IS/LL/P N	BS30T/IS/U/P N	BS30T/IS/S N	BS30T/IS/LL/S N	BS30T/IS/U/S N

Optional Extras for Borehole Pump Controls

Code	Description
EFS01	Ammeter Selector Switch up to 18.5kW
EFS02	Ammeter Selector Switch 22kW+
EFS03	Voltmeter 72 x 72, c/w Fuses - IP42
EFS04	Voltmeter Selector Switch
EFS05	Running Hour Meter 48 x 48
EFS19	Ammeter 72 x 72 - IP42 up to 18,5kW
EFS20	Ammeter 72 x 72 - IP42 22kW+

*Order float switch or probes separately. See page 51 & 52.

Note: When requesting a price or when ordering a starter with optional extra, please order optional extra as a separate line. Order example: 1) Borehole pump control 3 phase 5.5KW with isolator and liquid level control in a steel enclosure with running hour meter as optional extra.

Item 1: B12T/IS/LL/S N Item 2: EFS05

Wireless solutions available including GSM. Contact our Panel Workshop



TE05

Compact Borehole DOL Starter with TE03 Protection

With Contactor for motors up to 5.6kW @ 400V and 2.2kW @ 230V. Protection features: Dry run, locked rotor, overload, phase failure/reversal/imbalance, over/under voltage, auto calibration for easy commissioning and LED array for full status indication. Housed in compact IP56 polycarbonate enclosure with glands and on/off switch. Connection for float switch.

Code	Description	Size (H x W x D)
TE05M	Pump controller for 230V single phase motors up to 0.75kW	200 x 140 x 80mm
TE05M-1	Pump controller for 230V single phase motors 1.1 to 2.2kW	200 x 140 x 80mm
TE05Q	Pump controller for 400V three phase motors up to 4kW	200 x 140 x 80mm
TE05Q-1	Pump controller for 400V three phase motors 5.6kW	200 x 140 x 80mm
TE05N	Pump controller for 415V three phase motors up to 4kW	200 x 140 x 80mm
TE05N-1	Pump controller for 415V three phase motors up to 5,6kW	200 x 140 x 80mm

BOREHOLE PUMP CONTROLS



BETR3-055

Economy Borehole Control Panel IP43 - Size: 275 x 300 x 150mm

Weatherproof steel enclosed control panels with 3 conduit entries, On-off switch, Pump protection relay with provision for float switch, CT where required, Incoming isolator, Surge protection & contactor.

For features of the different protection relays, see pg 168 & 169

Motor 230V	FLC	UNO	TE03	TE03 + Ammeter
≤ 0.75kW	≤ 6A	BEUN1-015	BETE1-007	BETE1A-007
1.1kW	8.8A	BEUN1-015	BETE1-011	BETE1A-011
1.5kW	11.8A	BEUN1-015	BETE1-015	BETE1A-015
2.2kW	17A	BEUN1-022	BETE1-022	BETE1A-022

Motor 400V	FLC	TRIO	SUPRA	TE03	TE03 + Ammeter
≤ 4.0kW	9A	BETR3-055	-	BETE3-040	BETE3A-040
≤ 5.5kW	13.2A	BETR3-055	-	BETE3-055	BETE3A-055
7.5kW	17.8A	-	BESU3-075	BETE3-075	BETE3A-075



TRIO-SP5.6



TRIO-SP5.6/P



DOL Borehole Pump Control Panel with Motorscope Relay IP65

Fitted in IP65 steel or polycarbonate / ABS enclosure with Door-interlocked isolator, Surge protection, Contactor, Motorscope relay with protection fuses and CT. Door fitted with "POWER" on and "RUN" LED pilot-lights, Hand/Off/Auto selector switch and viewing window for Motorscope LED array. Provision for remote float switch.

Pump kW	Code		Enclosure Type	Size (H x W x D)
	400VAC	525VAC*		
0.37 - 5.6	TRIO-SP5.6/P	-	Plastic	400 x 300 x 180
0.37 - 5.6	TRIO-SP5.6*	SUPRA-5-SP11		400 x 300 x 200
7.5 - 11	SUPRA-SP11*	SUPRA-5-SP11	Steel	400 x 300 x 200
15	SUPRA-SP15*	SUPRA-5-SP15		400 x 300 x 200
22	SUPRA-SP22*	SUPRA-5-SP22		500 x 400 x 200
30	SUPRA-SP30*	SUPRA-5-SP30		500 x 400 x 200
37	SUPRA-SP37*	SUPRA-5-SP37		500 x 400 x 200
45	SUPRA-SP45*	SUPRA-5-SP45		600 x 400 x 260
55	SUPRA-SP55*	SUPRA-5-SP55		700 x 500 x 260
75	SUPRA-SP75*	SUPRA-5-SP75		700 x 500 x 260
90	-	SUPRA-5-SP90		700 x 500 x 260

* Add -PSL to code for pressure switch lock-out facility. * 525VAC Versions - 110V Control

Note: MOBI version available on special request at no extra charge for SUPRA versions



TRIO PANEL

Compact Borehole DOL Starter with Motorscope Protection

With Contactor for motors up to 5.6kW @ 400V. Protection features: Event memory, dry run, locked rotor, overload, phase failure/reversal/imbalance, over/under voltage, auto calibration for easy commissioning and LED array for full status indication. Housed in compact IP56 polycarbonate enclosure. Connection for float switch.

Code	Description	Size (H x W x D)
TRIO PANEL	Pump controller for 400V 3Ph Motors 0.37 - 5.6kW	300 x 220 x 180mm

COMPRESSOR STARTERS



AS15

Star-Delta starters with on-off selector switch and provision for pressure switch connection. 415V coils fitted. IP56

Code	Motor kW @ 400V	Size (H x W x D)
AS7.5	7.5kW	240 x 190 x 160mm
AS11	11kW	300 x 220 x 180mm
AS15	15kW	300 x 220 x 180mm

DOL STARTERS

Economy DOL Starters - 3ph



BE1-T40 (Steel)



Economy DOL Starters - 1ph



For 230V Single Phase motors,
Coil fitted,
U 240V
With Pre-Wired T1-L2 Link



kW AC3	Overload Range	DOL Starter IP65	DOL Starters with isolator IP65	DOL Starters with ammeter IP54	kW AC3	Overload Current Range Fitted	DOL Starter IP65 230V - 1PH
0.37kW	0.63-1.0A	LE1-D123N305	ILE1-D123N305	ALE1-D123N305	0.37kW	2.5 - 4A	LE1-D121U308
0.55kW	1.0 -1.6A	LE1-D123N306	ILE1-D123N306	ALE1-D123N306	0.55kW	4-6A	LE1-D121U310
0.75kW	1.6-2.5A	LE1-D123N307	ILE1-D123N307	ALE1-D123N307	0.75kW	4-6A	LE1-D121U310
1.1kW	1.6-2.5A	LE1-D123N307	ILE1-D123N307	ALE1-D123N307	1.1kW	7-10A	LE1-D121U314
1.5kW	2.5-4.0A	LE1-D123N308	ILE1-D123N308	ALE1-D123N308	1.5kW	9-13A	LE1-D121U316
2.2kW	4-6A	LE1-D123N310	ILE1-D123N310	ALE1-D123N310			
3kW	5.5-8A	LE1-D123N312	ILE1-D123N312	ALE1-D123N312			
4kW	7-10A	LE1-D123N314	ILE1-D123N314	ALE1-D123N314			
5.5kW	9-13A	LE1-D123N316	ILE1-D123N316	ALE1-D123N316			
7.5kW	12-18A	LE1-D183N321	ILE1-D183N321	ALE1-D183N321			
11kW	17-25A	LE1-D253N322	ILE1-D253N322	ALE1-D253N322			
15kW	23-32A	LE1-D323N353	ILE1-D323N353	ALE1-D323N353			
15kW	23-32A	BE1-T3235N353	-	-			
18.5kW	30-40A	BE1-T4035N355	-	-			
22kW	37-50A	BE1-T5036N357	-	-			
30kW	48-65A	BE1-T6535N361	-	-			
37kW	63-80A	BE1-T8035N363	-	-			
45kW	80-93A	BE1-T9535N343	-	-			

New wide range coil voltages

U 240V (170-280V)

N 415V (352-465V)

SF 550V (465-605V)

Ideal for agricultural applications

LE1 c/w plastic enclosure

BE1 c/w metal enclosure

DOL Starters without Overload



Code	Description
LE1-D123*	5.5kW
LE1-D183*	7.5kW
LE1-D253*	11kW
LE1-D323*	15kW

Coil voltage:

*SF 550V (465-605V)

*U 240V (170-280V)

*N 415V (352-465V)

Size: 195(L) x 100(W) x 145(D)



BE1-T40 (Steel)
275(L) x 160(W) x 145(D)



LE1-D32
195(L) x 100(W) x 145(D)

Accessories

Code	Description
LE1-D12	Empty enclosure c/w push buttons Up to 7.5kW
LE1-D25	For 11kW
LE1-D32	For 15kW
BE1-T40	For 18-24kW (Steel)
LA9-D09906	Start switch - Up to 7.5kW
LE1-DSBG	Green Start Button
LE1-DSBR	Red Stop Button

DOL STARTERS & DOL REVERSING STARTERS

DOL Starters - Optional extras: Isolator, Ammeter and choice of **IP65** Steel Enclosure or **IP56** Polycarbonate Enclosure. Starters can be customised by adding items from the **Optional Extras** table below.



Steel Enclosed
shown with isolator &
ammeter

Code	Motor kW @ 400V	Motor kW @ 550V	Overload Range	With Isolator	With Ammeter	Enclosure Material	Coil Voltage	Steel Encl. Size* H x W x D	Poly Encl. Size* H x W x D
ELC009	4kW	5.5kW	7-10A	/IS	/AM	/S or /P	B = 24V	300 x 250 x 200	240 x 190 x 160
ELC012	5.5kW	7.5kW	9-13A	/IS	/AM	/S or /P	BT* = 24V	300 x 250 x 200	240 x 190 x 160
ELC018	7.5kW	11kW	12-18A	/IS	/AM	/S or /P	E = 48V	300 x 250 x 200	240 x 190 x 160
ELC025	11kW	15kW	17-25A	/IS	/AM	/S or /P	F = 110V	300 x 250 x 200	300 x 220 x 180
ELC032	15kW	18.5kW	23-32A	/IS	/AM	/S or /P	FT* = 110V	300 x 250 x 200	300 x 220 x 180
ELC040	18.5kW	22kW	30-40A	/IS	/AM	/S	U = 240V	400 x 300 x 200	-
ELC050	22kW	30kW	37-50A	/IS	/AM	/S	UT* = 240V	400 x 300 x 200	-
ELC065	30kW	37kW	48-65A	/IS	/AM	/S	N = 415V	400 x 300 x 200	-
ELC080	37kW	45kW	63-80A	/IS	/AM	/S	SF = 550V	600 x 400 x 260	-
ELC095	45kW	55kW	80-93A	/IS	/AM	/S		600 x 400 x 260	-
ELC115	55kW	75kW	100-160A	/IS	/AM	/S	B = 24V	700 x 500 x 260	-
ELC150	75kW	90kW	100-160A	/IS	/AM	/S	F = 110V	800 x 600 x 320	-
ELC185	90kW	110kW	125-200A	/IS	/AM	/S	FT* = 110V	1000 x 600 x 320	-
ELC225	110kW	132kW	160-250A	/IS	/AM	/S	P = 230V	1000 x 600 x 320	-
ELC265	132kW	160kW	200-315	/IS	/AM	/S	PT* = 230V	1200 x 800 x 320	-
ELC330	160kW	220kW	250-400A	/IS	/AM	/S	V = 400V	1200 x 800 x 320	-
ELC400	220kW	275kW	315-500A	/IS	/AM	/S	SF = 550V	1675 x 600 x 400	-

Note: When requesting a price or when ordering a starter with optional extra from list below, please order optional extra as a separate line. Order example:

1) 4kW, 400V, with Isolator, Ammeter, Hour Meter, Phase Failure monitor, Steel enclosure, 240V coil.

Item 1: **ELC009/IS/AM/S U**

Item 2: **EFS05**

Item 3: **EFS18**

* Starter c/w Control Transformer. To specify Control Transformer primary voltage add: 4 (400V), 5 (550V).

DOL Reversing Starters - Complete with mechanical and electrical interlocks and thermal overload relay. Steel Enclosure **IP65** or Polycarbonate Enclosure **IP56**. Enclosed starters can be customised by adding items from **Optional Extras** table below.

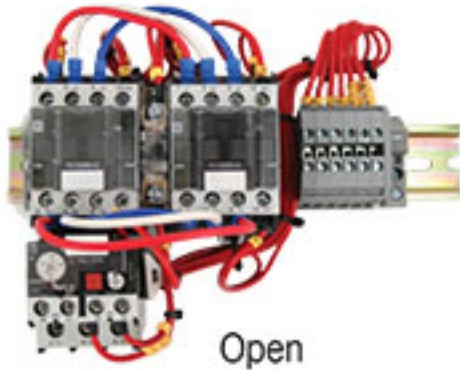

Open



Plastic Enclosed

Open Starter	Enclosed Starter	Motor kW @ 400VAC	Motor kW @ 550VAC	Overload Range	Standard Options		Enclosure Material	Coil Voltage	Enclosure Size* H x W x D
					Isolator	Ammeter			
RC009A	ERC009A	0.37kW	0.55kW	1-1.6A	/IS	/AM	/P	B = 24V	240 x 190 x 160
RC009B	ERC009B	0.55-0.75kW	1.5kW	1.6-2.5A	/IS	/AM	/P		240 x 190 x 160
RC009C	ERC009C	1.1-1.5kW	2.2kW	2.5-4A	/IS	/AM	/P	BT* = 24V	240 x 190 x 160
RC009D	ERC009D	2.2kW	3kW	4-6A	/IS	/AM	/P		240 x 190 x 160
RC009E	ERC009E	3kW	4kW	5.5-8A	/IS	/AM	/P	F = 110V	240 x 190 x 160
RC009	ERC009	4kW	5.5kW	7-10A	/IS	/AM	/P	FT* = 110V	240 x 190 x 160
RC012	ERC012	5.5kW	7.5kW	9-13A	/IS	/AM	/P		240 x 190 x 160
RC018	ERC018	7.5kW	11kW	12-18A	/IS	/AM	/P	U = 240V	240 x 190 x 160
RC025	ERC025	11kW	15kW	17-25A	/IS	/AM	/S		400 x 300 x 200
RC032	ERC032	15kW	18.5kW	23-32A	/IS	/AM	/S	UT* = 240V	400 x 300 x 200
RC40	ERC40	18.5kW	22kW	30-40A	/IS	/AM	/S		500 x 400 x 200
RC50	ERC50	22kW	30kW	37-50A	/IS	/AM	/S	N = 415V	500 x 400 x 200
RC65	ERC65	30kW	37kW	48-65A	/IS	/AM	/S		500 x 400 x 200
RC80	ERC80	37kW	45kW	63-80A	/IS	/AM	/S	SF = 550V	600 x 400 x 260

* Starter c/w Control Transformer. To specify Control Transformer primary voltage add: 4 (400V), 5 (550V).

Optional Extras - for Enclosed DOL Starters **ELC** Series & Reversing Starters **ERC** Series

*Standard panel sizes listed. Change /P or /S if required.

Note:

The selection of optional extras may impact on the enclosure size. For accurate quotation please contact our panel shop.

Code	Description	Code	Description
EFS01	Ammeter selector switch Up to 18.5kW	EFS10	Surge Protection - 3-phase, 40kA
EFS02	Ammeter selector switch 22kW+	EFS11	Surge Protection - 3-phase+N, 40kA
EFS03	Voltmeter 72x72, c/w fuses (IP42)	EFS12	Emergency Stop
EFS04	Voltmeter selector switch	EFS13	Man/Off/Auto selector
EFS05	Running Hour Meter 48x48	EFS14	Man/Off/Auto sel + 24VAC field circuit
EFS06	Surge Protection - 1-phase, 5kA	EFS15	Pilot light - Run - Green
EFS07	Surge Protection - 3-phase, 5kA	EFS16	Pilot Light - Trip - Red
EFS08	Surge Protection - 3-phase+N, 5kA	EFS17	Pilot Light - Power On - Amber
EFS09	Surge Protection - 1-phase, 40kA	EFS18	Phase Failure Relay

STAR-DELTA STARTERS

Star-Delta Starters - Complete with mechanical and electrical interlocks, thermal overload relay and electronic timer. Steel enclosure **IP65** or Polycarbonate Enclosure **IP56**. Enclosed starters can be customised by adding items from the **Optional Extras** table shown below. Control fuses fitted on enclosed starters $\geq 5.5\text{kW}$.

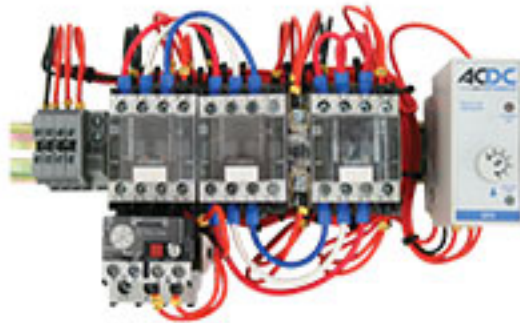

Open Type



EDC-Type - Plastic Enclosed



EDC-Type - Steel Enclosed

Open Starter	Enclosed Starter	Motor kW @400VAC	Motor kW @550VAC	Overload Range	Standard Options		Encl. Material*	Coil Voltage	Standard Encl. Size L x W x H
					Isolator	Ammeter			
DC009A	EDC009A	4kW	5.5kW	4-6A	/IS	/AM	/P	B = 24V	240 x 190 x 160
DC009B	EDC009B	5.5kW	7.5kW	5.5-8A	/IS	/AM	/P		240 x 190 x 160
DC009	EDC009	7.5kW	11kW	7-10A	/IS	/AM	/P	BT* = 24V	240 x 190 x 160
DC012	EDC012	11kW	15kW	9-13A	/IS	/AM	/P	F = 110V	240 x 190 x 160
DC018	EDC018	15kW	18.5kW	12-18A	/IS	/AM	/P		240 x 190 x 160
DC025	EDC025	18.5kW	22kW	17-25A	/IS	/AM	/P	FT* = 110V	300 x 220 x 180
DC032	EDC032	22kW	30kW	23-32A	/IS	/AM	/P	U = 240V	300 x 220 x 180
DC038	EDC038	30kW	37kW	28-36A	/IS	/AM	/P		300 x 220 x 180
DC040A	EDC040A	37kW	45kW	37-50A	/IS	/AM	/S	UT* = 240V	500 x 400 x 200
DC050	EDC050	45kW	55kW	37-50A	/IS	/AM	/S		600 x 400 x 260
DC065	EDC065	55kW	75kW	48-65	/IS	/AM	/S	N = 415V	600 x 400 x 260
DC080	EDC080	75kW	90kW	63-80A	/IS	/AM	/S	SF = 550V	700 x 500 x 260
DC095	EDC095	90kW	110kW	80-93A	/IS	/AM	/S		700 x 500 x 260
DC115	EDC115	110kW	132kW	100-160A	/IS	/AM	/S	B = 24V	1000 x 800 x 320
DC150	EDC150	132kW	160kW	100-160A	/IS	/AM	/S	BT* = 24V	1000 x 800 x 320
DC185	EDC185	160kW	200kW	125-200A	/IS	/AM	/S	F = 110V	1000 x 800 x 320
DC225	EDC225	220kW	250kW	160-250A	/IS	/AM	/S	FT* = 110V	1200 x 800 x 320
DC265	EDC265	250kW	315kW	200-315A	/IS	/AM	/S	P = 230V	1200 x 800 x 320
DC330	EDC330	315kW	400kW	250-400A	/IS	/AM	/S	PT* = 230V	1575 x 800 x 400
DC400	EDC400	375kW	450kW	315-500A	/IS	/AM	/S	V = 400V	1575 x 800 x 400
								SF = 550V	1575 x 800 x 400

* Change /P (Plastic) or /S (Steel) if required. Enclosed Dimensions shown are for standard option.

* Starter c/w Control Transformer. To specify Control Transformer primary voltage add: 4 (400V), 5 (550V).

Note: The selection of optional extras may impact the enclosure size. For accurate quotation contact our panel shop.

Note: When requesting a price or when ordering a starter with optional extras, order the optional extra as a separate line.

Order example: 1) 4kW, 400V, with Isolator, Ammeter, Hour Meter, Phase Failure monitor, Steel enclosure, 240V coil.

Item 1: EDC009/IS/AM/S U Item 2: EFS05 Item 3: EFS18

Star-Delta with Static Power Factor Correction (PFC) IP42

Complete with isolator, ammeter, mechanical and electrical interlocks, thermal overload relay, 2 x electronic timers, cooling fans, HRC control fuses, capacitor switching contactor and 3PH capacitor. Starters can be customised by adding items from the **Optional Extras** table shown below.

Code	Motor Kw @400VAC	Overload Range	Compensation @400V	Coil Voltage	Standard Encl. Size L x W x H
EDCP018	15kW	12 - 18A	4 kVAr	F = 110V	800 x 600 x 320
EDCP025	18.5kW	17 - 25A	6 kVAr		800 x 600 x 320
EDCP032	22kW	23 - 32A	8,5 kVAr		800 x 600 x 320
EDCP038	30kW	28 - 36A	10,5 kVAr	U = 240V	800 x 600 x 320
EDCP040A	37kW	37 - 50A	13 kVAr		800 x 600 x 320
EDCP050	45kW	37 - 50A	13 kVAr		800 x 600 x 320
EDCP065	55kW	48 - 65A	17 kVAr	N = 415V	800 x 600 x 320
EDCP080	75kW	63 - 80A	22 kVAr		800 x 600 x 320
EDCP095	90kW	80 - 93A	26 kVAr		1000 x 800 x 320
EDCP115	110kW	100 - 160A	29 kVAr	F = 110V P = 230V V = 400V	1200 x 800 x 320
EDCP150	132kW	100 - 160A	32 kVAr		1200 x 800 x 320



Note: Star-Delta starters with power factor correction are only available in ventilated steel enclosures. Compensation is calculated for 4 pole motors only, to meet or exceed 0.95 PF.

Optional Extras - for Enclosed Starters

Code	Description	Code	Description
EFS01	Ammeter selector switch Up to 18.5kW	EFS10	Surge Protection - 3-phase, 40kA
EFS02	Ammeter selector switch 22kW+	EFS11	Surge Protection - 3-phase+N, 40kA
EFS03	Voltmeter 72x72, c/w fuses (IP42)	EFS12	Emergency Stop Pushbutton
EFS04	Voltmeter selector switch	EFS13	Man/Off/Auto selector
EFS05	Running Hour Meter 48x48	EFS14	Man/Off/Auto sel + 24VAC field circuit
EFS06	Surge Protection - 1-phase + N, 5kA	EFS15	LED Pilot light - Run - Green
EFS07	Surge Protection - 3-phase, 5kA	EFS16	LED Pilot Light - Trip - Red
EFS08	Surge Protection - 3-phase + N, 5kA	EFS17	LED Pilot Light - Power On - Amber
EFS09	Surge Protection - 1-phase + N, 40kA	EFS18	Phase Failure Relay SPR3

Note: The selection of optional extras may impact on the enclosure size. For accurate quotation please contact our panel shop.

MANUAL MOTOR STARTERS

With thermal overload and magnetic short-circuit release



Phase failure sensitivity according to IEC 947-4-1
 Ambient temperature -25...+40°C (enclosed)
 Operating voltage U_e 690V
 Current heat loss 6.0W (total)
 Intrinsically safe up to 6kA @ 400VAC

Back-up fuses (gL, aM) [A]	kA			With Current Limiter NM1-SB kA		Adj. range	Code		
	230V	400V	500V	230V	400V				
No additional protective installations necessary.	25	35	50	3	100	0.1 - 0.16A	NM1-0.16		
						0.16 - 0.25A	NM1-0.25		
						0.25 - 0.40A	NM1-0.4		
						0.40 - 0.63A	NM1-0.63		
						0.63 - 1.0A	NM1-1		
						1.0 - 1.6A	NM1-1.6		
						1.6 - 2.5A	NM1-2.5		
						2.5 - 4.0A	NM1-4		
						4.0 - 6.3A	NM1-6.3		
						6.3 - 10A	NM1-10		
80	80	63	10	6	3	100	50	16 - 20A	NM1-16
80	80	63	10	6	3	100	50	20 - 25A	NM1-20
80	80	63	10	6	3	100	50	20 - 25A	NM1-25



NM1-G1



NM1-FP1

Enclosures & Fittings

Code	Description
NM1-G1	Surface mounting enclosure - IP55 Insulated with entries 4 x M20 threaded
NM1-FP1	Flush mounting enclosure - IP55 For flush-mounting in enclosures, switchboard or machines
NM1-PV	Emergency Stop Button - Latch-in, twist to release
NM1-VS	Padlock Device to lock an enclosed starter in the OFF position using up to 3 padlocks (6-8mm shackle)

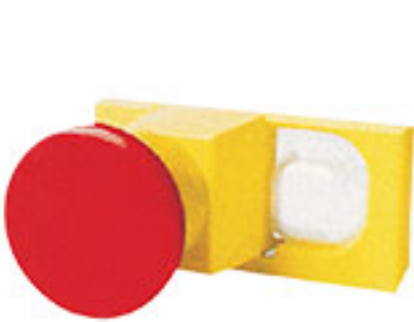

NM1-PV



NM1-VS

Accessories

Code	Description
NM1-HS11	Side mount Aux 1NO +1NC
NM1-HS02	UI = 500V Ith = 6A
NM1-EHS11	AC11: 3.5A at 250V, 2A at 400V
NM1-ESS01	*Side mount alarm contact 1NC

*Alarm contacts operate on thermal or magnetic trip. NC on tripped condition

Undervoltage Release (Internal Mounting)

NM1-U230V	Actuating voltage $\leq 85\% V_n$ Tripping voltage 35-75% V_n	230V
NM1-U400V	Rated duty 100% (uninterrupted) Heat Loss 1.8W	400V

Fitting of accessories: Internal mount, one per starter. Side mount, max two per starter.

Current Limiter

NM1-SB	For increasing the breaking capacity of not intrinsically safe MMS to 50kA at 400V. Rated continuous current 32A. Also for use as group back-up protection: 4 x 10 or 2 x 16A
--------	--

Busbars

NM1-B02	For starters without External Aux Contact	2 way 90mm
NM1-B03		3 way 136mm
NM1-B04		4 way 180mm
NM1-B12	For starters with RH External Aux fitted	2 way 99mm
NM1-B13		3 way 153mm
NM1-B14		4 way 207mm
NM1-B15		5 way 261mm



NM1-HS

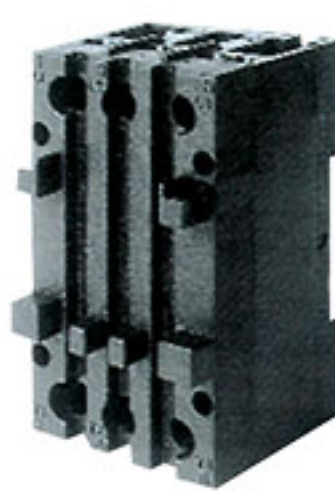

NM1-SB



NM1-U



NM1-B13

MOTOR PROTECTION CIRCUIT BREAKER MPCB

Motor Protection Circuit Breaker - 32A Frame - High Breaking Capacity



Code	Rated Operational Current I_n [A]	Thermal Release Adjustment Range [A]	Magnetic Release Operating Current [A]	400/415V		3-phase [kW] (50/60Hz)			
				I_{cu} [kA]	I_{cs} [kA]	230V	400V	500V	690V
TCMS-32H 0.16	0.16	0.1-0.16	2.1	100	100	-	0.02	-	-
TCMS-32H 0.25	0.25	0.16-0.25	3.3	100	100	0.03	0.06	-	-
TCMS-32H 0.4	0.4	0.25-0.4	5.2	100	100	0.06	0.09	-	-
TCMS-32H 0.63	0.63	0.4-0.63	8.2	100	100	0.09	0.12	0.25	0.25
TCMS-32H 1	1	0.63-1.0	13	100	100	0.12	0.25	0.37	0.55
TCMS-32H 1.6	1.6	1.0-1.6	20.8	100	100	0.25	0.55	0.55/0.75	1.1
TCMS-32H 2.5	2.5	1.6-2.5	32.5	100	100	0.37	0.75	1.1	1.5
TCMS-32H 4	4	2.5-4.0	52	100	100	0.75	1.5	1.5/2.2	3
TCMS-32H 6	6	4-6	78	100	100	1.5	2.2	3	4
TCMS-32H 8	8	5-8	104	100	100	1.5	3	3.7	5.5
TCMS-32H 10	10	6-10	130	100	100	3	4	4/5.5	7.5
TCMS-32H 13	13	9-13	169	100	100	3	5.5	7.5	11
TCMS-32H 17	17	11-17	221	50	38	4	7.5	11	11
TCMS-32H 22	22	14-22	286	50	38	4	7.5	11	15
TCMS-32H 26	26	18-26	338	50	38	5.5	11	15	18.5
TCMS-32H 32	32	22-32	416	50	38	7.5	15	18.5	22

Motor Protection Circuit Breaker - 63A Frame - High Breaking Capacity



Code	Rated Operational Current I_n [A]	Thermal Release Adjustment Range [A]	Magnetic Release Operating Current [A]	400/415V		3-phase [kW] (50/60Hz)			
				I_{cu} [kA]	I_{cs} [kA]	230V	400V	500V	690V
TCMS-63H 32	32	22-32	416	50	50	7.5	15	18.5	22
TCMS-63H 40	40	28-40	520	50	50	7.5	18.5	22	30
TCMS-63H 50	50	34-50	650	50	50	11	22	30	45
TCMS-63H 63	63	45-63	819	50	50	15	30	37	55

Motor Protection Circuit Breaker - 100A Frame - High Breaking Capacity



Code	Rated Operational Current I_n [A]	Thermal Release Adjustment Range [A]	Magnetic Release Operating Current [A]	400/415V		3-phase [kW] (50/60Hz)			
				I_{cu} [kA]	I_{cs} [kA]	230V	400V	500V	690V
TCMS-100H 63	63	45-63	819	100	50	15	30	37	55
TCMS-100H 75	75	55-75	975	100	50	22	37	45	63
TCMS-100H 90	90	70-90	1170	100	50	30	45	55	75
TCMS-100H 100	100	80-100	1300	100	50	30	45	63	90

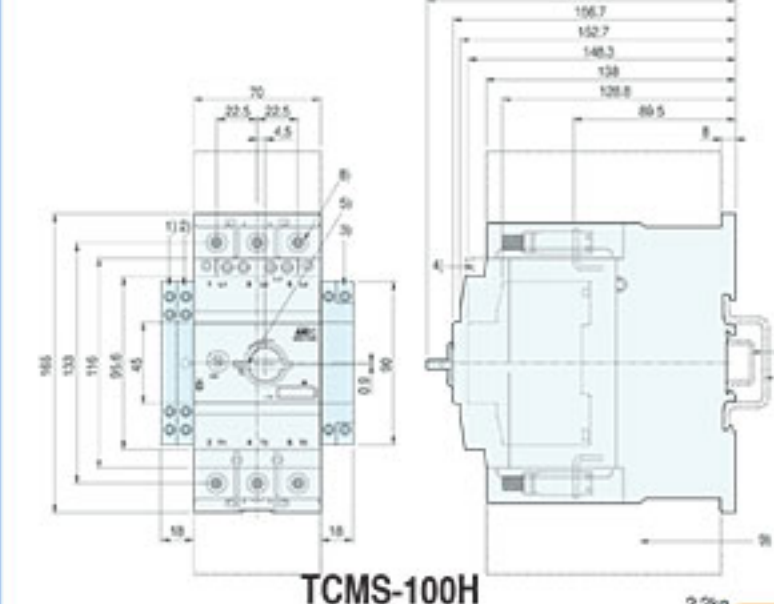
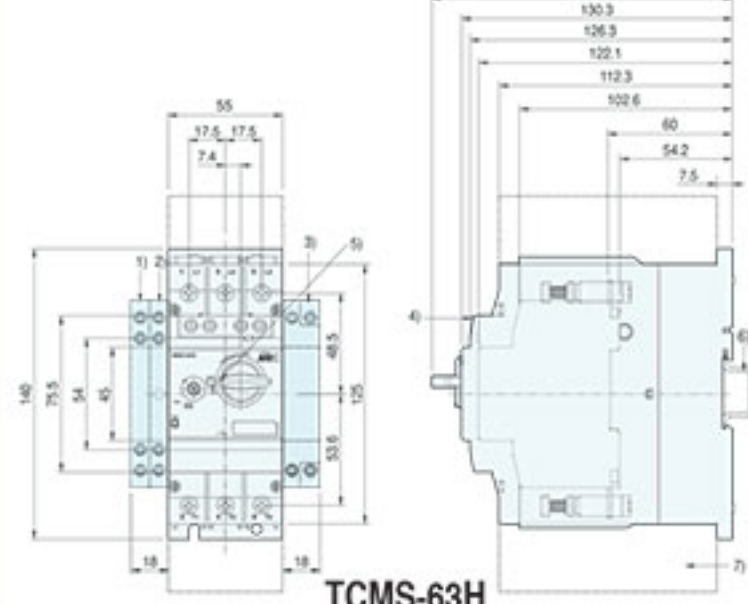
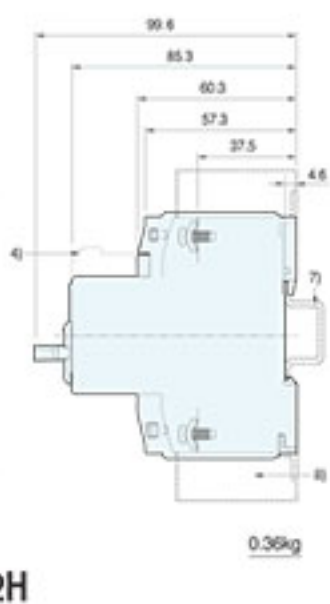
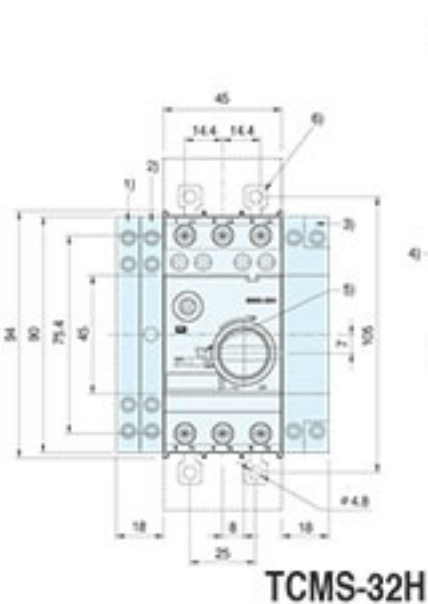

MOTOR PROTECTION CIRCUIT BREAKER MPCB



TFX



TLX



TLA, TLAM

Accessories

Code	Description
------	-------------

Auxiliary Contacts

- TFX Front mounting Auxiliary contacts - One module per MPCB
- TLX Left side mounting Auxiliary contacts - One module per MPCB
- TLX modules can be stacked on top of TLA and TLAM alarm contacts

TFX-11 Aux Switch for MPCB front mounting - 1NO1NC

TFX-20 Aux Switch for MPCB front mounting - 2NO

TFX-02 Aux Switch for MPCB front mounting - 2NC

TLX-11 Aux Switch for MPCB left side mounting - 1NO1NC

TLX-20 Aux Switch for MPCB left side mounting - 2NO

TLX-02 Aux Switch for MPCB left side mounting - 2NC

Alarm Contacts

- Alarm contacts must be installed first when being used with TLX module
- TLA and TLAM modules cannot be stacked together
- Refer to diagram on left for maximum configuration

TLA-11* Trip Alarm Switch for MPCB left side mounting - 1NO1NC

TLA-20* Trip Alarm Switch for MPCB left side mounting - 2NO

TLA-02* Trip Alarm Switch for MPCB left side mounting - 2NC

TLAM-11 Magnetic Trip Alarm Switch for MPCB left side mounting - 1NO1NC

TLAM-20 Magnetic Trip Alarm Switch for MPCB left side mounting - 2NO

TLAM-02 Magnetic Trip Alarm Switch for MPCB left side mounting - 2NC

* Add -63 to code for 63/100A frame

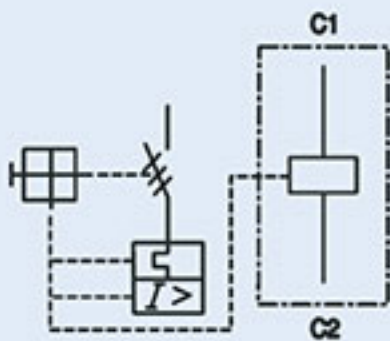

Shunt Release

- Right side mounting
- One right side mounting module per MPCB

TRS-24V 24V - 28V 50Hz

TRS-110V 110V - 127V 50Hz

TRS-230V 220V - 230V 50Hz

TRS-400V 415V - 440V 50Hz

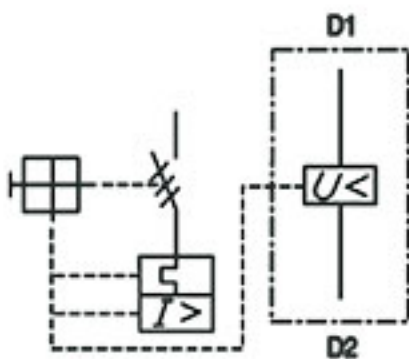

Undervoltage Release

- Right side mounting
- One right side mounting module per MPCB

TRU-24V 24V - 28V 50Hz

TRU-110V 110V - 127V 50Hz

TRU-230V 220V - 230V 50Hz

TRU-400V 415V - 440V 50Hz

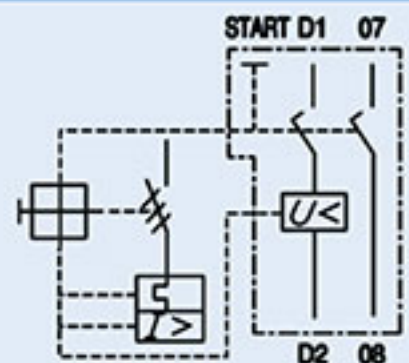

Undervoltage Release with Auxiliary

- Right side mounting
- Includes 2 NO Aux
- One right side mounting module per MPCB

TRUX-110V 110V - 127V 50Hz

TRUX-230V 220V - 230V 50Hz

TRUX-400V 415V - 440V 50Hz

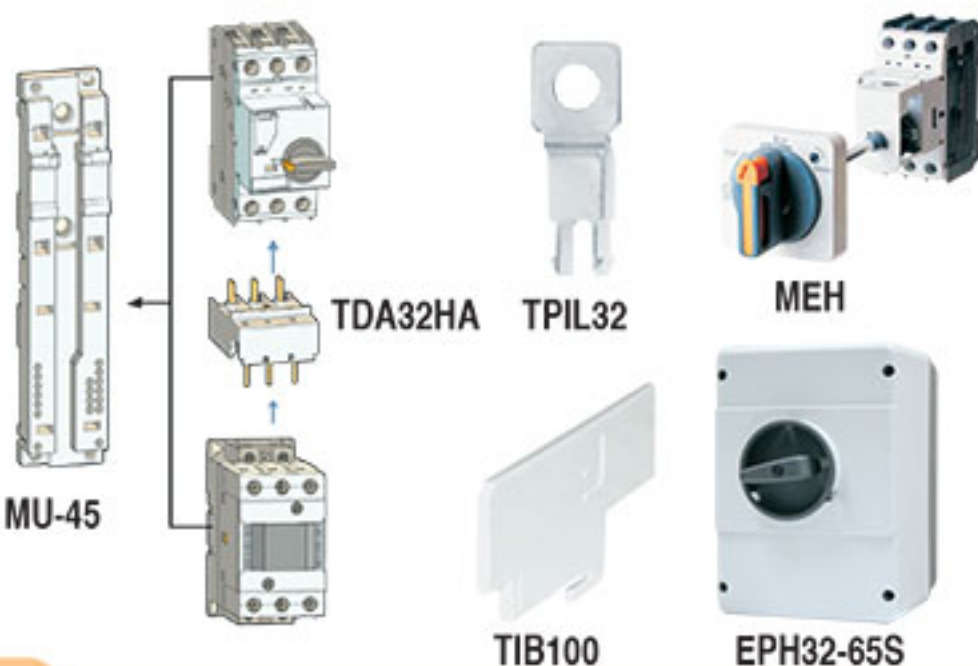

Mounting Accessories

TIB100 Insulation barrier for TCMS-100

EPH32-65S IP65 enclosure to accommodate TCMS-32

TDA32HA* Direct adaptor used to connect TCMS-32 directly with a mini contactor

MU45* Mounting unit to connect TCMS-32 with a mini contactor

MEH32-115 Pad-lockable vari-depth rotary handle for use with TCMS-32

MEH63-115 Pad-lockable vari-depth rotary handle for use with TCMS-63

MEH100-115 Pad-lockable vari-depth rotary handle for use with TCMS-100

*Items used for Type 2 co-ordination (See Chart in Technical Section).

VACUUM CONTACTORS

Vacuum Contactors - 3P



Code	Rated Current	Rated Voltage	Rated Making Capacity	Rated Breaking Capacity	Auxiliary Contacts	Mechanical Life	Electrical Life	Pick-Up Power (W)	Hold Power (W)	Weight
CKJ11-160/1.5*	160A	1.5kV	1600A	1280A	3NO/1NC	1 000 000	60 000	265W	30W	3.5kg
CKJ11-250/1.5*	250A	1.5kV	2500A	2000A	3NO/1NC	1 000 000	60 000	265W	30W	5kg
CKJ11-400/1.5*	400A	1.5kV	4000A	3200A	4NO/1NC	1 000 000	60 000	342W	38W	7.5kg
CKJ11-630/3.6*	630A	3.6kV	6300A	5000A	4NO/2NC	1 000 000	60 000	400W	45W	10kg

*Add Control Voltage to code: 110V, 230V, 400V - All sizes supplied with auxiliary contacts

2 POLE CONTACTORS

2 Pole Contactors - Suitable for air conditioners



TCDP

Code	Rating A (AC1)	No. of Poles	Terminals
TCDP202*	20A	2 N/O	Screw/PushOn
TCDP302*	30A	2 N/O	Screw/PushOn
TCDP402*	40A	2 N/O	Screw/PushOn

*Add coil voltage: M = 240VAC, Q = 400VAC

Heavy Duty Relay

G7LB-2A*	25A	2 N/O	Clamp
----------	-----	-------	-------

*Add coil voltage: 24VAC, 110VAC, 230VAC



G7LB-2A

MINI CONTACTORS



Code	Auxiliary Contacts	Max ratings for application of 3-phase motors - AC3		Max ratings for application on resistive heating loads - AC1
FDC-K0910*	N/O	9A@400V	4kW@400V	20A@400V
FDC-K0901*	N/C	9A@400V	4kW@400V	20A@400V

*Add coil voltage: B = 24VAC, F = 110VAC, M = 230VAC, Q = 400VAC

Spare Coil Code FDC-D2* *Add voltage: B = 24VAC, F = 110VAC, M = 230VAC, Q = 400VAC

MOTOR START PUSH BUTTONS

Direct Motor Starters for Three Phase Motors

Rated Volts: 550VAC
Cable Entry: 20mm
IP42



IP42



Code	SP-315	SP-330	SY-315	SY-330
Rated Current	15A	30A	15A	30A
Rated Power	0-2.2kW	0-3.7kW	0-2.2kW	0-3.7kW
Mounting	Surface	Surface	Flush	Flush
Material	Steel	Steel	Steel	Steel

Single Phase

Three Phase

Code	SDZ-6A	SDZ-6B	SDZ-6E	SDZ-08B	SDZ08-8
Rated Current	15A	15A	15A	15A	12A (AC-3)
Rated Power	2.2kW (AC-3)	2.2kW (AC-3)	2.2kW (AC-3)	2.2kW (AC-3)	3PH 400VAC
Cutout Size	50 x 23mm	50 x 23mm	46 x 22mm	Surface Mount	Surface Mount

• Power Failure Protection

• Under Voltage Protection

MINI 3-POLE CONTACTORS & OVERLOAD RELAYS



Electronic Timer

Coil Suppressor



Auxiliary Contact configurations

Current AC3@415V	6A	9A	12A	16A
Code* 1N/O Aux	TC1-M0610*	TC1-M0910*	TC1-M1210*	TC1-M1610*
Code* 1N/C Aux	TC1-M0601*	TC1-M0901*	TC1-M1201*	TC1-M1601*
Rated operating voltage	690VAC	690VAC	690VAC	690VAC
AC1 Duty Resistive Load	20A	20A	20A	20A
AC3 Duty Current rating	6A@380/440V	9A@380/440V	12A@380/440V	16A@380/440V
AC3 Duty Power rating	2.2kW@380/440V	4kW@380/440V	5.5kW@380/440V	7.5kW@380/440V
AC3 Duty Power rating	3kW@500/550V	3.7kW@500/550V	4kW@500/550V	5.5kW@500/550V
Coil Consumption Inrush/sealed	32/6VA	32/6VA	32/6VA	32/6VA
Mechanical life (million ops)	12	12	12	12
Electrical life (million ops)	1	1	1	1
Size H x W x D	58 x 45 x 57mm	58 x 45 x 57mm	58 x 45 x 57mm	58 x 45 x 57mm
Mounting Rail	DIN / Chassis	DIN / Chassis	DIN / Chassis	DIN / Chassis

*Add coil voltage to code: B = 24VAC E = 48VAC F = 110VAC M = 220VAC N = 415VAC



Aux & Coil Terminals Extended through overload Ambient compensated -5°C to 40°C

Thermal Overload Relay for use with mini contactors - c/w 1NO+1NC Auxiliary Contacts

Code	Relay Range	KW @400V	Code	Relay Range	KW @400V
TR2-M0.14A	0.10-0.16A	-	TR2-M3.3A	2.5-4A	1.5kW
TR2-M0.21A	0.16-0.25A	-	TR2-M5A	4-6A	2.2kW
TR2-M0.33A	0.25-0.4A	0.06-0.9kW*	TR2-M6.5A	5-8A	3.kW
TR2-M0.52A	0.4-0.63A	0.12-0.15kW*	TR2-M7.5A	6-9A	4kW
TR2-M0.82A	0.63-1A	0.25kW-0.37kW*	TR2-M8.5A	7-10A	4.0kW
TR2-M1.3A	1-1.6A	0.55kW	TR2-M11A	9-13A	5.5kW
TR2-M2.1A	1.6-2.5A	0.75-1.1kW	TR2-M14A	12-16A	7.5kW

* Check Motor Rating Plate First

Automatic/Manual reset site selectable

Auxiliaries Top And Side Mount - Ith = 10A



Code	Contact Configuration	Mounting	Code	Contact Configuration	Mounting
TA1-M20	2NO	Front	TA1-M22	2NO + 2NC	Front
TA1-M11	1NO + 1NC	Front	TA1-M13	1NO + 3NC	Front
TA1-M02	2NC	Front	TA1-M04	4NC	Front
TA1-M40	4NO	Front	TA8-M01	1NC	Side
TA1-M31	3NO + 1NC	Front	TA8-M10	1NO	Side

Accessories



Coil Suppressor

TA9-M978

Code	Description
TA9-M978	Mechanical Interlock for TC1-M06-M16 for horizontal mounting
TA9-M980-1	Coil Suppressor for 24-48VAC coils
TA9-M980-2	Coil Suppressor for 60-127VAC coils
TA9-M980-3	Coil Suppressor for 200-240VAC coils

AC Mini Control Relay - Ith = 20AUc = 690VAC



Code	Contact Configuration
TCA2-M22*	2NO + 2NC
TCA2-M31*	3NO + 1NC
TCA2-M40*	4NO
TCA2-M13*	1NO + 3NC
TCA2-M04*	4NC

*Add coil voltage to code: B = 24VAC E = 48VAC F = 110VAC M = 220VAC N = 415VAC

AC CONTACTORS & OVERLOADS

NEW IMPROVED DESIGN

3 & 4 Pole Contactors AC Coil

with Front Dust Cover

UL SF CB Certification



All ratings are for ambient temperature upto 40°C and 2000m above sea level.

D09-D95 supplied with wide range coils



Code* 1N/O Aux	TC1-	D0910	D1210	D1810	D2210	D2510	D3210	D3810	D40	D50	D65	D80	D95
Code* 1N/C Aux	TC1-	D0901	D1201	D1801	D2201	D2501	D3201	D3801	1NO+1NC	1NO+1NC	1NO+1NC	1NO+1NC	1NO+1NC
Code* 4 Pole Contactors	TC1-	D09004	D12004	D18004	-	D25004	-	-	D40004	D50004	D65004	D80004	D95004
Code* 4 Pole 2NO/2NC	TC1-	D09008	D12008	-	-	D25008	-	-	D40008	D50008	D65008	D80008	D95008
Rated operating voltage	AC	690V	690V	690V	690V	690V	690V	690V	690V	690V	690V	690V	690V
AC1 Duty Resistive Load		25A	25A	32A	32A	40A	50A	50A	60A	80A	80A	125A	125A
AC3 Duty Current rating	400V	9A	12A	18A	22A	25A	32A	38A	40A	50A	65A	80A	95A
AC3 Duty Power rating	400V	4kW	5.5kW	7.5kW	11kW	11kW	15kW	18.5kW	18.5kW	22kW	30kW	37kW	45kW
	550V	5.5kW	7.5kW	11kW	12.5kW	15kW	18.5kW	18.5kW	22kW	30kW	37kW	45kW	55kW
	1000V	-	-	-	-	-	-	-	-	-	-	-	-
AC4 Duty 200K ops	400V	2.2kW	3.7kW	4kW	4.5kW	5.5kW	7.5kW	7.5kW	9kW	11kW	11kW	15kW	15kW
Star-Delta Power rating	400V	7.5kW	11kW	15kW	15kW	18.5kW	22kW	30kW	37kW	45kW	55kW	75kW	90kW
	550V	7.5kW	11kW	18.5kW	18.5kW	22kW	37kW	37kW	45kW	55kW	75kW	90kW	110kW
Generator Set	400V	17kVA	17kVA	22kVA	22kVA	27kVA	34kVA	38kVA	42kVA	55kVA	55kVA	85kVA	85kVA
Electrical life (million ops)	AC3	3.6	3.6	3.6	3.6	3.6	3.6	3.6	3.6	3.6	3.6	3.6	3.6
Power Dissipation/Pole	AC1	1.56W	1.56W	2.5W	2.5W	3.2W	5W	5W	5.4W	9.6W	6.4W	12.5W	12.5W
Coil Consumption Inrush/sealed	50Hz	60/7VA				90/7.5VA			200/20VA				
Cable Size required for AC 1 Duty	50/60Hz	4mm ²	4mm ²	6mm ²	6mm ²	10mm ²	10mm ²	10mm ²	16mm ²	25mm ²	25mm ²	35mm ²	35mm ²
	Size H x W x D - 3 Pole	mm	74 x 45 x 80				84 x 56 x 93			127 x 75 x 114			127 x 85 x 125
Mounting Rail	DIN	35mm				35mm			35/70mm			35/70mm	

Spare Coils

Code	TX1-D2*	TX1-D4*	TX1-D6*
Coil Voltages*	  		
J = 12V 50/60Hz (10.2-13.2V)			
B = 24V 50/60Hz (20.4-26.4V)			
E = 48V 50/60Hz (41-53V)			
F = 110V 50/60Hz (77-121V)			
U = 240V 50Hz (170-280V)			
	N = 415V 50Hz (352-465V) S = 500V 50Hz (425-550V) SF = 550V 50Hz (467-605V)		

Thermal Overload Relays



Code	Range	kW@400V	Code	Range	Code	Range	kW@400V
TR2-D09303	0.25 - 0.40A	0.06-0.9kW*			TR2-D40353	23 - 32A	15kW
TR2-D09304	0.40 - 0.63A	0.12-0.18kW*			TR2-D40355	30 - 40A	18.5kW
TR2-D09305	0.63 - 1.00A	0.25-0.37kW*			TR2-D65357	37 - 50A	22kW
TR2-D09306	1.00 - 1.60A	0.55kW	TR2-D25322	17 - 25A	TR2-D65359	48 - 65A	25 - 30kW
TR2-D09307	1.60 - 2.50A	0.75-1.1kW	(11kW@400V)		TR2-D65361	55 - 70A	30 - 37kW
TR2-D09308	2.50 - 4.00A	1.5kW	TR2-D32353	23 - 32A	TR2-D80363	63 - 80A	37kW
TR2-D09310	4.00 - 6.00A	2.2kW	(15kW@400V)		TR2-D95365	80 - 93A	45kW
TR2-D09312	5.50 - 8.00A	3.0kW	TR2-D32355	28 - 36A			
TR2-D09314	7.00 - 10.00A	4.0kW	(18.5kW@400V)				
TR2-D12316	9.00 - 13.00A	5.5kW					
TR2-D18321	12.00 - 18.00A	7.5kW					

* Check Motor Rating Plate First

1000V CONTACTORS & OVERLOADS

World class accreditation
UL508-17th edition
CSA22.2 No.14-95
CB Certification



LC1-FDP...

115A	150A	185A	225A	265A	330A	400A	500A	630A	780A*
Use same auxiliaries as TC1 contactors. Each contactor accepts up to 2 add-on units. Refer to page 3									
1154A	1504A	1854A	2254A	2654A	3304A	4004A	5004A	6304A	7804A*
-	-	-	-	-	-	-	-	-	-
1000V	1000V	1000V	1000V	1000V	1000V	1000V	1000V	1000V	1000V
200A	250A	275A	315A	350A	400A	500A	700A	1000A	1600A
115A	150A	185A	225A	265A	330A	400A	500A	630A	780A
55kW	75kW	90kW	110kW	132kW	160kW	200kW	250kW	335kW	400kW
75kW	90kW	110kW	129kW	160kW	200kW	257kW	355kW	400kW	450kW
65kW	75kW	100kW	100kW	147kW	160kW	185kW	335kW	450kW	450kW
18.5kW	22kW	40kW	45kW	55kW	63kW	75kW	80kW	100kW	110kW
110kW	132kW	160kW	200kW	250kW	315kW	375kW	-	-	-
132kW	160kW	220kW	250kW	315kW	375kW	425kW	-	-	-
135kVA	165kVA	185kVA	225kVA	240kVA	280kVA	350kVA	475kVA	680kVA	1100kVA
2.4	2.4	2.4	2.4	2.4	2.4	2.4	2.4	1.2	0.8
18W	25W	26W	-	39W	-	70W	88W	120W	250W
550/45VA	550/45VA	805/55VA	805/55VA	1200/95VA	700/10VA	1075/15VA	1100/18VA	1650/22VA	2100/50VA
50mm ²	70mm ²	95mm ²	Flexibar 24 x 4mm	Flexibar 24 x 4mm	Flexibar 24 x 4mm	Flexibar 24 x 5mm	Flexibar 24 x 5mm	Flexibar 24 x 10mm	Flexibar 50 x 5mm
162 x 164 x 173		174 x 169 x 185	197 x 169 x 185	203 x 202 x 207	206 x 206 x 223	206 x 213 x 226	238 x 233 x 238	304 x 309 x 260	434 x 702 x 250

Chassis Mounted

* 2 x Coils - Coils to be Ordered Separately

AC Coils

Code	LX1-FF*	LX1-FG*	LX1-FH2*	LX1-FJ*	LX1-FK*	LX1-FL*	LX1-FX*
------	---------	---------	----------	---------	---------	---------	---------

Coil Voltages*

- B = 24V 50Hz (20.4-26.4V)
- E = 48V 50Hz (41-53V)
- F = 110V 50Hz (77-121V)
- P = 230V 50Hz (195-253V)
- V = 400V 50Hz (340-440V)
- S = 500V 50Hz (425-550V)
- SF = 550V 50Hz (467-605V)



LX1 Coil

Overload Base Plate

DIN or Screw Mount



Code	To Fit Overload Sizes
TA7-D0964	From TR2-D09301 To TR2-D25322
TA7-D3264	From TR2-D32353 To TR2-D32355
TA7-D4064	From TR2-D40353 To TR2-D95365



Thermal Overload Relays

Internal CT's, Separate Mounting, 1000V Rated

Code	Range	Motor@400V
LR1-F(M)105	65 - 105A	37 - 55kW
LR1-F160	100 - 160A	75 - 90kW
LR1-F200	125 - 200A	90 - 110kW
LR1-F250	160 - 250A	110 - 132kW
LR1-F315	200 - 315A	132 - 160kW
LR1-F400	250 - 400A	160 - 220kW
LR1-F500	315 - 500A	200 - 250kW
LR1-F630	400 - 630A	250 - 375kW

Electronic Overload Relays

Internal CT's, Separate Mounting, 1000V Rated

Code	Range	Motor@400V
LR9-F5367	60-100A	90 - 110kW
LR9-F5369	90-150A	110 - 132kW
LR9-F5371	132-220A	132 - 160kW
LR9-F7375	200-330A	160 - 220kW
LR9-F7379	300-500A	200 - 250kW
LR9-F7381	380-630A	250 - 375kW

For more electronic overloads, see pages 169-172



CONTACTORS & CONTROL RELAYS

3 Pole Contactors DC Coils



D09-D80
supplied with coil

Code* 1N/O Aux	TP1-	D0910*	D1210*	D1810*	D2510*	D3210*	D4011*	D5011*	D6511*	D8011*
Code* 1N/C Aux	TP1-	D0901*	D1201*	D1801*	D2501*	D3201*	1NO+1NC	1NO+1NC	1NO+1NC	1NO+1NC
AC3 Rated Power @ 400V		4kW	5.5kW	7.5kW	11kW	15kW	18.5kW	22kW	30kW	37kW
Coil Consumption		9W	9W	9W	11W	11W	22W	22W	22W	22W
Mechanical Life (million ops)		30	30	30	25	25	20	20	20	20
Dimensions H x W x D mm		74 x 45 x 115			84 x 56 x 130		127 x 75 x 168		127 x 85 x 181	



Spare Coils

Code	TX4-D2*	TX4-D4*	LX4-D40*	LX4-D80*
------	---------	---------	----------	----------

* Voltage DC JD = 12VDC BD = 24VDC ED = 48VDC FD = 110VDC MD = 220VDC

Contactors for 3 Phase PF Correction Capacitors

Internal diagram of Contactor

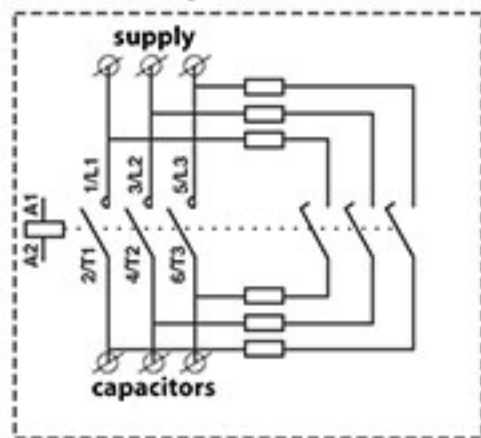

Conforms to AC6b
IEC 60947-4-1

D12K-D75K
supplied with coil



Code* 1N/O + 1N/C	TC1-	D12K11*	D16K11*	D20K11*	D25K11*	D33K12*	D40K12*	D60K12*	D75K12*
Code* 2N/C	TC1-	D12K02*	D16K02*	D20K02*	D25K02*	1NO+2NC	1NO+2NC	1NO+2NC	1NO+2NC
Rated operating voltage		690V	690V	690V	690V	690V	690V	690V	690V
Capacitor switching	400V	12.5kVAr	16.7kVAr	20kVAr	25kVAr	33.3kVAr	40kVAr	60kVAr	75kVAr

* Add Coil Voltage F = 110V 50/60Hz U = 240V 50Hz N = 415V 50Hz

Reversing Contactors (Wide range of AC coils AC Coils)

AC Control Relays

DC Control Relays



Code	AC3 400V	Aux Contacts	Code	Contacts	Code	Contacts
TC2-D0901*	4kW	1N.C.	TCA2-DN22*	2N.O. + 2N.C.	TCA3-DN22*	2N.O. + 2N.C.
TC2-D1201*	5.5kW	1N.C.	TCA2-DN31*	3N.O. + 1N.C.	TCA3-DN31*	3N.O. + 1N.C.
TC2-D1801*	7.5kW	1N.C.	TCA2-DN40*	4N.O.	TCA3-DN40*	4N.O.
TC2-D2501*	11kW	1N.C.	Uc = 12-600V		Uc = 12-600V	
TC2-D3201*	15kW	1N.C.	Ith = 10A		Ith = 10A	
TC2-D4011*	18.5kW	1N.O. + 1N.C.	Max ops per sec = 3		Max ops per sec = 3	
TC2-D5011*	22kW	1N.O. + 1N.C.	Mechanical life:		Mechanical life:	
TC2-D6511*	30kW	1N.O. + 1N.C.	50Hz coil 20m ops		DC coil 30m ops	
TC2-D8011*	37kW	1N.O. + 1N.C.	50/60Hz coil 30m ops			
TC2-D9511*	45kW	1N.O. + 1N.C.				

* Coil Voltage AC J = 12V 50Hz (9-32A only) B = 24V 50/60Hz E = 48V 50/60Hz F = 110V 50/60Hz U = 240V 50Hz N = 415V 50Hz SF = 550V 50Hz V = 400V 50Hz P = 230V 50Hz S = 500V 50Hz

* Coil Voltage DC JD = 12VDC BD = 24VDC ED = 48VDC FD = 110VDC MD = 220VDC

ACCESSORIES



Auxiliaries - Top Mount
Fits directly onto all T & F range contactors & TCA2 Relays

Code	Description
TA1-DN11	1N.O. + 1N.C.
TA1-DN02	2N.C.
TA1-DN20	2N.O.
TA1-DN22	2N.O. + 2N.C.
TA1-DN13	1N.O. + 3N.C.
TA1-DN31	3N.O. + 1N.C.
TA1-DN40	4N.O.
TA1-DN04	4N.C.



Auxiliaries - Side Mount
T Range Contactors from 9Amp to 38Amp frame sizes and TCA2 and TCA3 Relays only

Code	Description
TA8-DN11	1N.O. + 1N.C.
TA8-DN20	2N.O.

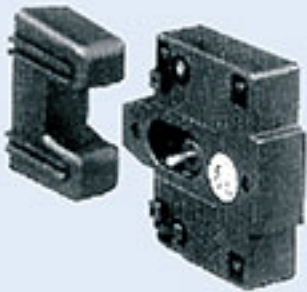

Horizontal Mechanical Interlocks
T Range only

Code	For use with Contactors
CA9-D10	TC1-D09 to D38 c/w 2N.C.
TA9-D09978	TC1-D09 to D38 & TCA2
TA9-D50978	TC1-D40 to D65
TA9-D80978	TC1-D80 to D95



Coil Suppressor

Code	For use with Contactors
TA9-AMOV980E	D09 to D95 24-48VAC/DC
TA9-AMOV980U	D09 to D95 110-240VAC/DC
TA9-RC980N	D09 to D95 380-440VAC



Pneumatic Timers
Fits directly onto all T & F Range Contactors & TCA2 Relays

Code	Description
TA2-DT2	Delay On 0-30sec
TA2-DT4	0-180sec
TA3-DR2	Delay Off 0-30sec
TA3-DR4	0-180sec
TA2-DS2	S/Delta 1-30sec*

*With 40ms pause between Star opening & Delta closing.



Mechanical Latching Block
Fitted with 230VAC release coil

Code	For use with Contactors
LA6-DK01 P	D09 to D32 contactors and TCA2 relays

T-Range



Rev/S-D Power Kits - Set of 6

Code	For use with Contactors
TA9-D1269	TC1-D09 to D12
TA9-D1869	TC1-D18 & D22
TA9-D2569	TC1-D25
TA9-D3269	TC1-D32 & D38
TA9-D6569	TC1-D40 to D65
TA9-D8069	TC1-D80 to D95



1 set

F Range Accessories



Set of 6



F Range Contactor Size	Reversing/Star-Delta Busbar Kits	Star Point Bridge	Horizontal Mechanical Interlocks	Vertical Mechanical Interlocks	Contact Kits (No. of Poles)	ARC Chambers (No. of Poles)
115A	LA9-F115CL	LA9-F115SP	LA9-FF970	LA9-FF971	LA5-FF431-F115(3)	LA5-FDP11550(3)
150A	LA9-F150CL	LA9-F185SP	LA9-FF970	LA9-FF971	LA5-FF431-F150(3)	LA5-FDP15050(3)
185A	LA9-F185CL	LA9-F185SP	LA9-FG970	LA9-FG971	LA5-FG431-F185(3)	LA5-FDP18550(3)
225A	LA9-F225CL	LA9-F400SP	LA9-FG970	LA9-FG971	LA5-FG431-F225(3)	LA5-FDP22550(3)
265A	LA9-F265CL	LA9-F400SP	LA9-FJ970	LA9-FH971	LA5-FH431-F265(3)	LA5-FDP26550(3)
330A	LA9-F400CL	LA9-F400SP	LA9-FJ970	LA9-FH971	LA5-F400803-F330(3)	LA5-FDP33050(3)
400A	LA9-F400CL	LA9-F400SP	LA9-FJ970	LA9-FJ971	LA5-F400803-F400(3)	LA5-FDP40050(3)
500A	LA9-F500CL	LA9-F500SP	LA9-FJ970	LA9-FK971	LA5-F500803-F500(3)	LA5-FDP50050(3)
630A	LA9-F630CL	LA9-F630SP	LA9-FL970	LA9-FL971	LA5-F630803-F630(3)	LA5-FDP63050(3)
780A	-	-	-	LA9-FX970	LA5-F780801-F780(1)	LA5-FDP78050(1)

NEW

WINBREAK1 ADJUSTABLE MCCBs

- Conforms to IEC60947-2 | Suitable for Isolation
- Range 16A-400A 3 & 4 Pole
- Breaking capacity: 25kA 35/36kA 50kA
- Trip Free mechanism
- Neutral with 100% rated current | Bounce free contact structure
- Wide range of internal & external accessories
- Standard packing includes insulating phase barrier for line side and hardware
- Cascading and Discrimination available
- Type one and Type two co-ordination available
- Ui: 750V Uimp: 8kV



CSE1M125ATM3P-100A



CSE1M125ATM4P-100A



CSE2S250ATM3P-250A



CSE3S400ATM3P-320A

Dimensions: (W x H x D)

- Frame 1: 3P - 92 x 150 x 81mm
4P - 123 x 150 x 81mm
- Frame 2: 3P - 108 x 166 x 81mm
4P - 143 x 166 x 81mm
- Frame 3: 3P - 150 x 260 x 110mm
4P - 198 x 260 x 110mm

Adjustable Thermal Magnetic Moulded Case Circuit Breakers

Code 3 Pole	Code 4 Pole	Breaking Capacity Icu@415VAC	Rated Current (A)	Frame
Adjustable Overload 80 - 100% - Adjustable Short Circuit 5-10 In - Ics = 50% Icu				
CSE1S125FMU3P-16A	CSE1S125FMU4P-16A	50KA	16 (13-16)	1
CSE1S125FMU3P-20A	CSE1S125FMU4P-20A		20 (16-20)	1
CSE1S125FMU3P-25A	CSE1S125FMU4P-25A		25 (20-25)	1
CSE1S125FMU3P-32A	CSE1S125FMU4P-32A		32 (26-32)	1
CSE1S125FMU3P-40A	CSE1S125FMU4P-40A		40 (32-40)	1
CSE1S125FMU3P-50A	CSE1S125FMU4P-50A		50 (40-50)	1
CSE1S125ATM3P-63A	CSE1S125ATM4P-63A		63 (50-63)	1
CSE1S125ATM3P-80A	CSE1S125ATM4P-80A		80 (64-80)	1
CSE1S125ATM3P-100A	CSE1S125ATM4P-100A		100 (80-100)	1
CSE1S125ATM3P-125A	CSE1S125ATM4P-125A		125 (100-125)	1
Adjustable Overload:80 - 100% - Adjustable Short Circuit: 5-10In, Ics = 100% Icu				
CSE1M125ATM3P-63A	CSE1M125ATM4P-63A	25KA	63 (50-63)	1
CSE1M125ATM3P-80A	CSE1M125ATM4P-80A		80 (64-80)	1
CSE1M125ATM3P-100A	CSE1M125ATM4P-100A		100 (80-100)	1
CSE1M125ATM3P-125A	CSE1M125ATM4P-125A		125 (100-125)	1
CSE2M250ATM3P-160A	CSE2M250ATM4P-160A		160 (128-160)	2
CSE2M250ATM3P-200A	CSE2M250ATM4P-200A		200 (160-200)	2
CSE2M250ATM3P-250A	CSE2M250ATM4P-250A	250 (200-250)	2	
CSE3M400ATM3P-320A	CSE3M400ATM4P-320A	320 (256-320)	3	
CSE3M400ATM3P-350A	CSE3M400ATM4P-350A	350 (280-350)	3	
CSE3M400ATM3P-400A	CSE3M400ATM4P-400A	400 (320-400)	3	
CSE1N125ATM3P-63A	CSE1N125ATM4P-63A	35KA	63 (50-63)	1
CSE1N125ATM3P-80A	CSE1N125ATM4P-80A		80 (64-80)	1
CSE1N125ATM3P-100A	CSE1N125ATM4P-100A		100 (80-100)	1
CSE1N125ATM3P-125A	CSE1N125ATM4P-125A		125 (100-125)	1
CSE2N250ATM3P-160A	CSE2N250ATM4P-160A		160 (128-160)	2
CSE2N250ATM3P-200A	CSE2N250ATM4P-200A		200 (160-200)	2
CSE2N250ATM3P-250A	CSE2N250ATM4P-250A	250 (200-250)	2	
CSE3N400ATM3P-320A	CSE3N400ATM4P-320A	36KA	320 (256-320)	3
CSE3N400ATM3P-350A	CSE3N400ATM4P-350A		350 (280-350)	3
CSE3N400ATM3P-400A	CSE3N400ATM4P-400A		400 (320-400)	3
CSE3S400ATM3P-320A	CSE3S400ATM4P-320A	50KA	320 (256-320)	3
CSE3S400ATM3P-350A	CSE3S400ATM4P-350A		350 (280-350)	3
CSE3S400ATM3P-400A	CSE3S400ATM4P-400A		400 (320-400)	3

NEW WINBREAK1 ADJUSTABLE MCCBs & ACCESSORIES

- IEC60947-2 Certified • Suitable for Isolation
- Adjustable over current $I_r = 0.4 - 1$ times I_n
- Adjustable short circuit 2 - 12 times I_r
- Built-in groundfault protection 20 - 100% of I_n
- Adjustable neutral overload protection: 50 - 100% of I_r
- Adjustable current imbalance protection available: 30-70% of I_r
- Provision of thermal memory: On/Off
- Communication: RS485 Modbus Protocol
- View last trip information I LCD: Display
- U_i : 750V, U_{imp} : 8kV

Dimensions: (W x H x D)

Frame 1: 3P - 92 x 150 x 81mm
 4P - 123 x 150 x 81mm
 Frame 2: 3P - 108 x 166 x 81mm
 4P - 143 x 166 x 81mm



3 Pole - 100A



4 Pole - 40A



4 Pole - 63A

Adjustable Electronic - Microprocessor Release MCCBs

Code 3 Pole	Code 4 Pole	Breaking Capacity Icu @ 415VAC	Rated Current (A)	Size (Frame)
CSE1N125ETM3P-40A	CSE1N125ETM4P-40A	25KA	16 - 40	1
CSE1N125ETM3P-63A	CSE1N125ETM4P-63A		25 - 63	1
CSE1N125ETM3P-100A	CSE1N125ETM4P-100A		40 - 100	1
CSE1N125ETM3P-125A	CSE1N125ETM4P-125A		50 - 125	1
CSE2N250ETM3P-160A	CSE2N250ETM4P-160A		63 - 160	2
CSE2N250ETM3P-200A	CSE2N250ETM4P-200A		80 - 200	2
CSE2N250ETM3P-250A	CSE2N250ETM4P-250A		100 - 250	2

Adjustable Overload 40-100% - Adjustable Short Circuit 2-12I_r - ICS = 100% ICU

Liquid Crystal Display

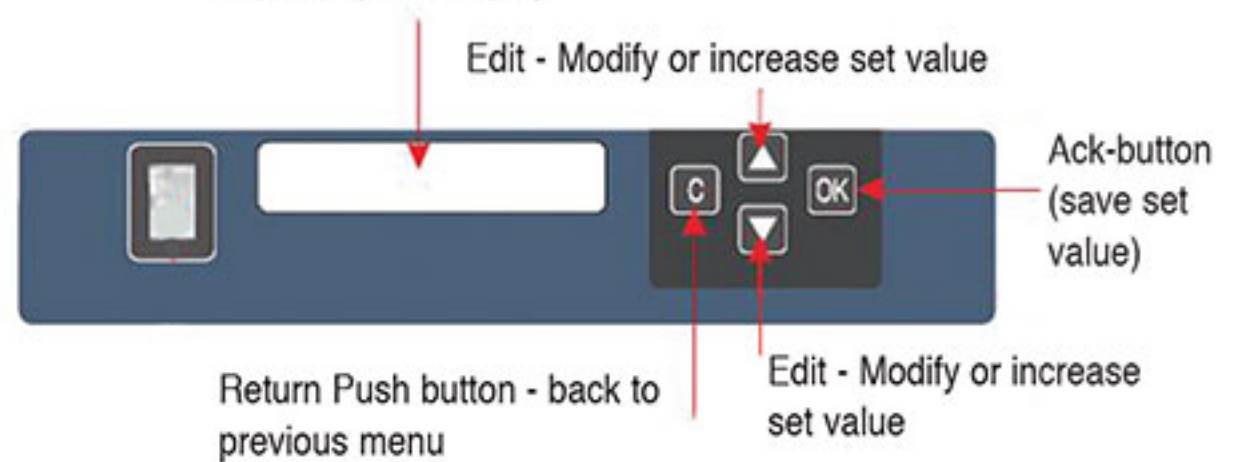

Auxillary & Alarm Switches

Frame	Auxillary Switches		Alarm Switches	
	Left	Right	Left	Right
1, 2	AXW1-L	AXW1-R	ALW1-L	ALW1-R
3	AXW1-3L	AXW1-3R	ALW1-3L	ALW1-3R



AXW1-3L



ALW1-R



STW1-220VAC/DC



UVTW-415VAC

Shunt & Under Voltage Trips

Frame	Shunt Trip (STW)	Under Voltage Trip
1, 2	STW1-24VDC	UVTW1-24VDC
	STW1-48VDC	UVTW1-48VDC
	STW1-110VDC	UVTW1-110VDC
	STW1-220VAC/DC	UVTW1-220VAC/DC
	STW1-415VAC	UVTW1-415VAC
3	STW1-3-24VDC	-
	STW1-3-48VDC	-
	STW1-3-110VDC	UVTW1-3-110VAC
	STW1-3-220VAC/DC	UVTW1-3-220VAC/DC
	STW1-3-415VAC	UVTW1-3-415VAC

Panel Mount Rotary Operating Handles

Frame	Code c/w Shaft	Code Key Lock
1 (150mm Shaft)	EHW1-125	EXTKLWB1-125AF-T1
2 (150mm Shaft)	EHW1-250	EXTKLWB1-250AF-T1
3 (200mm Shaft)	EHW1-400	EXTKLWB1-400AF-T1



EHW1-250

Extention Bars

Frame	Code 3 Pole	Code 4 Pole	Current Rating (A)
1	CSET1033	CSET1044	Up to 63A
1	CSET1033C	CSET1044C	Up to 125A
2	CSET2533	CSET2544	Up to 250A
3	CSETETW14033	CSETETW14044	Up to 400A



CSET2533

NEW

WINBREAK FIXED MCCB

- IEC 60947-2 Certified | Positive Isolation
- Trip Free Mechanism
- Standard Packaging includes phase barriers for line side and hardware
- Cascading and Discrimination available
- Type one and Type two co-ordination available
- Ui: 750V, Uimp: 8kV

Fixed Thermal & Magnetic Moulded Case Circuit Breakers

Code 3 Pole	Code 4 Pole	Breaking Capacity Icu@415VAC	*Rated Current (A)	Frame
Fixed Overload - Fixed short circuit - Ics=100%Icu				
CSC1S3*	CSC1S4*	18kA	15,20,30,40,50	1
CSC2N3*	CSC2N4*		60,75,100	
CSC4N3*	CSC4N4*		150,175,200,250	
CSC3S3*	CSC3S4*	37kA	15,20,30,40,50,60	2
CSC4S3*	CSC4S4*		75,100,125	
CSC5N3*	CSC5N4*		150,175,200,250	
CSC6N3*	CSC6N4*	50kA	300,350,400♦	4
CSC3H3*	CSC3H4*		500,630,700, 800	
CSC4H3*	CSC4H4*		15,20,30,40,50,60,	
CSC5H3*	CSC5H4*	65kA	75,100,125,	2
CSC6H3*	CSC6H4*		150,175,200,250	
CSC7S3*	CSC7S4*		300,350,400♦	
CSC8S3*	CSC8S4*	65kA Ics = 50% Icu	1000♦	6
CSC5L3*	CSC5L4*		1200♦	
CSC6L3*	CSC6L4*		300,350,400♦	
CSC7L3*	CSC7L4*	85kA	500,630,700,800	5
CSC8L3*	CSC8L4*		1000♦	
CSC8L3*	CSC8L4*		1200♦	

* Add Amps to Code. ♦ Spreader Bar Included

Auxillary & Alarm Switches

Frame	Auxillary Switches (AX)		Alarm Switches (AL)	
	Left	Right	Left	Right
1, 2, 3	AXWC-R	AXWC-T	AXWC-T	AXWC-R
4, 5	ASW-6A	ASW-6A	ASW-6A	ASW-6A
6	ASW-7A	ASW-7A	ASW-7A	ASW-7A

Shunt & Under Voltage Trips (See the Short Form Catalogue for Maximum Configurations)

Frame	Shunt Trip (SHT)	Under Voltage Trip (UVT)
1, 2, 3	STC-24VAC/DC	UVTC-24VAC/DC
	STC-48VAC/DC	UVTC-48VAC/DC
	STC-100-130VAC/DC	UVTC-100-110VAC/DC
	STC-200-250VAC/DC	UVTC-200-220VAC/DC
	STC-380-450VAC	UVTC-380-400VAC
	STC-440-550VAC	UVTC-440-480VAC
4, 5	ST-6A-24-48VAC/DC	UVT-6A-100-125VAC
	ST-6A-100-220VDC	UVT-6A-100-110VDC
	ST-6A-100-240VAC	UVT-6A-200-240VAC
	ST-6A-380-550VAC	UVT-6A-380-400VAC
6	ST-7A-200-220VAC	UVT-7A-200-220VAC

Handles

Frame	Direct Rotary Handle	Direct Rotary Handle with Key Lock	Extended Rotary Handle + Shaft
1	DHC100	DHCK100	EHC100 (470mm)
2	DHC125	DHCK125	EHC125 (470mm)
3	DHC250	DHCK250	EHC250 (470mm)
4	N70S	-	E70U (304mm)
5	-	-	E80U (304mm)

Terminal Covers - For Line & Load

Frame	3P Code	4P Code
1	TCS13	TCS14
2	TCS23	TCS24
3	TCS33	TCS34

Extention Bars - Supplied in half sets of 3 or 4

Frame	Code 3P	Code 4P	Current Rating (A)
1, 2	CSET1033	CSET1044	Up to 60A
1, 2	CSET1033C	CSET1044C	Up to 125A
3	CSET2533	CSET2544	Up to 250A
4	CSET8033	CSET8044	Up to 800A



CSC2N3



CSC3H3



CSC4H4



CSC5H3



CSC6S4



AXWC-T



ASW-6A



UVTC



DHC100



DHCK100



EHC100



TCS13



CSET1033C

Dimensions: (W x H x D) 3P

- Frame 1: 75 x 130 x 60mm
- Frame 2: 90 x 155 x 60mm
- Frame 3: 105 x 165 x 60mm
- Frame 4: 140 x 257 x 109mm
- Frame 5: 210 x 280 x 109mm
- Frame 6: 220 x 400 x 105mm

NEW

6KA CIRCUIT BREAKERS

Rated voltage: 240/415VAC
 Thermal Magnetic Release
 Rated Insulation Voltage Ui: 660V
 Rated Impulse Voltage Uimp: 4kV
 Integrated Label Holder
 Accepts Pin / Fork Busbar
 Electrical and Mechanical life:
 <32A - 30 000 operations
 >32A - 10 000 operations
 Energy limiting class: ELC3
 Terminal Capacity: 35mm²
 Ambient working Temperature:
 -25°C to 55°C
 60VDC capacity for 1P, 110VDC for 2P
 DIN Modules: 1M = 17,5mm



CSMBS1C1X



CSMBS2C1X



CSMBS3C1X

6kA C-Curve Miniature Din Rail Circuit Breakers IP20 IEC60947-2 / VC8036

Amps	1 Pole Code 1M Wide	1P+N Code 2M Wide	2 Pole Code 2M Wide	3 Pole Code 3M Wide	4 Pole Code 4M Wide
1A	CSMBS1C1X	CSMBS1C1NX	CSMBS2C1X	CSMBS3C1X	CSMBS4C1X
2A	CSMBS1C2X	CSMBS1C2NX	CSMBS2C2X	CSMBS3C2X	CSMBS4C2X
3A	CSMBS1C3X	CSMBS1C3NX	CSMBS2C3X	CSMBS3C3X	CSMBS4C3X
4A	CSMBS1C4X	CSMBS1C4NX	CSMBS2C4X	CSMBS3C4X	CSMBS4C4X
5A	CSMBS1C5X	CSMBS1C5NX	CSMBS2C5X	CSMBS3C5X	CSMBS4C5X
6A	CSMBS1C6X	CSMBS1C6NX	CSMBS2C6X	CSMBS3C6X	CSMBS4C6X
10A	CSMBS1C10X	CSMBS1C10NX	CSMBS2C10X	CSMBS3C10X	CSMBS4C10X
16A	CSMBS1C16X	CSMBS1C16NX	CSMBS2C16X	CSMBS3C16X	CSMBS4C16X
20A	CSMBS1C20X	CSMBS1C20NX	CSMBS2C20X	CSMBS3C20X	CSMBS4C20X
25A	CSMBS1C25X	CSMBS1C25NX	CSMBS2C25X	CSMBS3C25X	CSMBS4C25X
32A	CSMBS1C32X	CSMBS1C32NX	CSMBS2C32X	CSMBS3C32X	CSMBS4C32X
40A	CSMBS1C40X	CSMBS1C40NX	CSMBS2C40X	CSMBS3C40X	CSMBS4C40X
50A	CSMBS1C50X	CSMBS1C50NX	CSMBS2C50X	CSMBS3C50X	CSMBS4C50X
63A	CSMBS1C63X	CSMBS1C63NX	CSMBS2C63X	CSMBS3C63X	CSMBS4C63X

6kA D-Curve Miniature Din Rail Circuit Breakers IP20 IEC60947-2 / VC8036

Amps	1 Pole Code 1M Wide	1P+N Code 2M Wide	2 Pole Code 2M Wide	3 Pole Code 3M Wide	4 Pole Code 4M Wide
6A	CSMBS1D6X	CSMBS1D6NX	CSMBS2D6X	CSMBS3D6X	CSMBS4D6X
10A	CSMBS1D10X	CSMBS1D10NX	CSMBS2D10X	CSMBS3D10X	CSMBS4D10X
16A	CSMBS1D16X	CSMBS1D16NX	CSMBS2D16X	CSMBS3D16X	CSMBS4D16X
20A	CSMBS1D20X	CSMBS1D20NX	CSMBS2D20X	CSMBS3D20X	CSMBS4D20X
25A	CSMBS1D25X	CSMBS1D25NX	CSMBS2D25X	CSMBS3D25X	CSMBS4D25X
32A	CSMBS1D32X	CSMBS1D32NX	CSMBS2D32X	CSMBS3D32X	CSMBS4D32X
40A	CSMBS1D40X	CSMBS1D40NX	CSMBS2D40X	CSMBS3D40X	CSMBS4D40X
50A	CSMBS1D50X	CSMBS1D50NX	CSMBS2D50X	CSMBS3D50X	CSMBS4D50X
63A	CSMBS1D63X	CSMBS1D63NX	CSMBS2D63X	CSMBS3D63X	CSMBS4D63X

Tripping Characteristic: AC
 Rated Voltage: 240V - 2P
 415V - 4P
 Rated Insulation Voltage: 660V
 Rated Impulse Voltage: 6kV
 Terminal Capacity: 25mm²
 Mechanical / Electrical Life:
 20000/10000 Operations



CSRB2P25A300



CSRB4P40A100

6kA Residual Current Circuit Breakers (Earth Leakage Relays) Without Overload VC8035

Amps	2 Pole Code 2M Wide 240V	Leakage Current	Amps	4 Pole Code 4M Wide 415V	Leakage Current
25A	CSRB2P25A30	30mA	25A	CSRB4P25A30	30mA
25A	CSRB2P25A300	300mA	25A	CSRB4P25A300	300mA
32A	CSRB2P32A30	30mA	32A	CSRB4P32A30	30mA
32A	CSRB2P32A300	300mA	32A	CSRB4P32A300	300mA
40A	CSRB2P40A30	30mA	40A	CSRB4P40A30	30mA
40A	CSRB2P40A300	300mA	40A	CSRB4P40A300	300mA
63A	CSRB2P63A30	30mA	63A	CSRB4P63A30	30mA
63A	CSRB2P63A300	300mA	63A	CSRB4P63A300	300mA
80A	CSRB2P80A30	30mA	80A	CSRB4P80A30	30mA
80A	CSRB2P80A300	300mA	80A	CSRB4P80A300	300mA
100A	CSRB2P100A30	30mA	100A	CSRB4P100A30	30mA
100A	CSRB2P100A300	300mA	100A	CSRB4P100A300	300mA

NEW

10KA CIRCUIT BREAKERS

Rated voltage: 240/415VAC
 Thermal Magnetic Release
 Rated Insulation Voltage Ui: 660V
 Rated Impulse Voltage Uimp: 4kV
 Integrated Label Holder
 Accepts Pin / Fork Busbar
 Electrical and Mechanical life:
 <32A - 30 000 operations
 >32A - 10 000 operations
 Energy limiting class: ELC3
 Terminal Capacity: 35mm²
 Ambient working Temperature:
 -25°C to 55°C
60VDC capacity for 1P, 110VDC for 2P
 DIN Modules: 1M = 17,5mm



CSMBS1C6



CSMNS1C10N



CSMBS3C10

Tripping Characteristic: AC
 Rated Voltage: 240V - 2P
 415V - 4P
 Rated Insulation Voltage: 660V
 Rated Impulse Voltage: 6kV
 Terminal Capacity: 25mm²
 Mechanical / Electrical Life:
 20000/10000 Operations



CSRB2P40A100



CSRN4P40A100

10kA C-Curve Miniature Din Rail Circuit Breakers IP20, IEC 60947-2 / VC8036

Amps	1 Pole Code 1M Wide	1P+N Code 2M Wide	2 Pole Code 2M Wide	3 Pole Code 3M Wide	4 Pole Code 4M Wide
1A	CSMBS1C1	CSMBS1C1N	CSMBS2C1	CSMBS3C1	CSMBS4C1
2A	CSMBS1C2	CSMBS1C2N	CSMBS2C2	CSMBS3C2	CSMBS4C2
3A	CSMBS1C3	CSMBS1C3N	CSMBS2C3	CSMBS3C3	CSMBS4C3
4A	CSMBS1C4	CSMBS1C4N	CSMBS2C4	CSMBS3C4	CSMBS4C4
5A	CSMBS1C5	CSMBS1C5N	CSMBS2C5	CSMBS3C5	CSMBS4C5
6A	CSMBS1C6	CSMBS1C6N	CSMBS2C6	CSMBS3C6	CSMBS4C6
10A	CSMBS1C10	CSMBS1C10N	CSMBS2C10	CSMBS3C10	CSMBS4C10
16A	CSMBS1C16	CSMBS1C16N	CSMBS2C16	CSMBS3C16	CSMBS4C16
20A	CSMBS1C20	CSMBS1C20N	CSMBS2C20	CSMBS3C20	CSMBS4C20
25A	CSMBS1C25	CSMBS1C25N	CSMBS2C25	CSMBS3C25	CSMBS4C25
32A	CSMBS1C32	CSMBS1C32N	CSMBS2C32	CSMBS3C32	CSMBS4C32
40A	CSMBS1C40	CSMBS1C40N	CSMBS2C40	CSMBS3C40	CSMBS4C40
50A	CSMBS1C50	CSMBS1C50N	CSMBS2C50	CSMBS3C50	CSMBS4C50
63A	CSMBS1C63	CSMBS1C63N	CSMBS2C63	CSMBS3C63	CSMBS4C63

10kA C-Curve Miniature Din Rail Circuit Breakers IP20, IEC 60947-2 / VC8036

Amps	1 Pole Code 1,5M Wide	1P+N Code 3M Wide	2 Pole Code 3M Wide	3 Pole Code 4,5M Wide	4 Pole Code 6M Wide
80A	CSMBS1C80	CSMBS1C80N	CSMBS2C80		
100A	CSMBS1C100	CSMBS1C100N	CSMBS2C100		

10kA D-Curve Miniature Din Rail Circuit Breakers IP20, IEC 60947-2 / VC8036

Amps	1 Pole Code 1M Wide	1P+N Code 2M Wide	2 Pole Code 2M Wide	3 Pole Code 3M Wide	4 Pole Code 4M Wide
6A	CSMBS1D6	CSMBS1D6N	CSMBS2D6	CSMBS3D6	CSMBS4D6
10A	CSMBS1D10	CSMBS1D10N	CSMBS2D10	CSMBS3D10	CSMBS4D10
16A	CSMBS1D16	CSMBS1D16N	CSMBS2D16	CSMBS3D16	CSMBS4D16
20A	CSMBS1D20	CSMBS1D20N	CSMBS2D20	CSMBS3D20	CSMBS4D20
25A	CSMBS1D25	CSMBS1D25N	CSMBS2D25	CSMBS3D25	CSMBS4D25
32A	CSMBS1D32	CSMBS1D32N	CSMBS2D32	CSMBS3D32	CSMBS4D32
40A	CSMBS1D40	CSMBS1D40N	CSMBS2D40	CSMBS3D40	CSMBS4D40
50A	CSMBS1D50	CSMBS1D50N	CSMBS2D50	CSMBS3D50	CSMBS4D50
63A	CSMBS1D63	CSMBS1D63N	CSMBS2D63	CSMBS3D63	CSMBS4D63

10kA D-Curve Miniature Din Rail Circuit Breakers IP20, IEC 60947-2 / VC8036

Amps	1 Pole Code 1,5M Wide	1P+N Code 3M Wide	2 Pole Code 3M Wide	3 Pole Code 4,5M Wide	4 Pole Code 6M Wide
80A	CSMBS1D80	CSMBS1D80N	CSMBS2D80	CSMBS3D80	CSMBS4D80
100A	CSMBS1D100	CSMBS1D100N	CSMBS2D100	CSMBS3D100	CSMBS4D100

10kA Residual Current Circuit Breakers (Earth Leakage Relays) Without Overload VC8035

Amps	2 Pole Code 2M Wide 240V	Leakage Current	Amps	4 Pole Code 4M Wide 415V	Leakage Current
25A	CSRB2P25A30-10KA	30mA	25A	CSRB4P25A30-10KA	30mA
25A	CSRB2P25A300-10KA	300mA	25A	CSRB4P25A300-10KA	300mA
32A	CSRB2P32A30-10KA	30mA	32A	CSRB4P32A30-10KA	30mA
32A	CSRB2P32A300-10KA	300mA	32A	CSRB4P32A300-10KA	300mA
40A	CSRB2P40A30-10KA	30mA	40A	CSRB4P40A30-10KA	30mA
40A	CSRB2P40A300-10KA	300mA	40A	CSRB4P40A300-10KA	300mA
63A	CSRB2P63A30-10KA	30mA	63A	CSRB4P63A30-10KA	30mA
63A	CSRB2P63A300-10KA	300mA	63A	CSRB4P63A300-10KA	300mA
80A	CSRB2P80A30-10KA	30mA	80A	CSRB4P80A30-10KA	30mA
80A	CSRB2P80A300-10KA	300mA	80A	CSRB4P80A300-10KA	300mA
100A	CSRB2P100A30-10KA	30mA	100A	CSRB4P100A30-10KA	30mA
100A	CSRB2P100A300-10KA	300mA	100A	CSRB4P100A300-10KA	300mA

NEW

DC BREAKERS

Rated Voltage 12-220VDC over one pole
 Rated Insulation Voltage 660V
 Ambient Working Temperature: -5°C - 55°C
 Terminal Capacity: 35mm²
 Rated Impulse Voltage Uimp: 4kV
 Mechanical / Electrical Life:
 1000 Operations



CSMBS2DC32

10kA DC Miniature DIN Rail Circuit Breakers IP20

Amps	1 Pole Code 1M Wide 12-220VDC	2 Pole 2M Wide 12-220VDC
0.5A	CSMBS1DC0.5	CSMBS2DC0.5
1A	CSMBS1DC1	CSMBS2DC1
2A	CSMBS1DC2	CSMBS2DC2
3A	CSMBS1DC3	CSMBS2DC3
4A	CSMBS1DC4	CSMBS2DC4
5A	CSMBS1DC5	CSMBS2DC5
6A	CSMBS1DC6	CSMBS2DC6
10A	CSMBS1DC10	CSMBS2DC10
16A	CSMBS1DC16	CSMBS2DC16
20A	CSMBS1DC20	CSMBS2DC20
25A	CSMBS1DC25	CSMBS2DC25
32A	CSMBS1DC32	CSMBS2DC32
40A	CSMBS1DC40	CSMBS2DC40
50A	CSMBS1DC50	CSMBS2DC50
63A	CSMBS1DC63	CSMBS2DC63

NEW

ISOLATORS

Rated insulation voltage Ui: 660V
 Rated Impulse Voltage Uimp: 6kV
 Electrical & Mechanical life: <32A - 30 000 operations
 >32A - 10 000

Terminal Capacity: 35mm²
 Integrated Label Holder
 Accepts Pin / Fork Busbar



CSMB2ISO25



CSMB4ISO63

Amps	1 Pole Code 1M Wide	2 Pole Code 2M Wide	3 Pole Code 3M Wide	4 Pole Code 4M Wide
25A	CSMB1ISO25	CSMB2ISO25	CSMB3ISO25	CSMB4ISO25
40A	CSMB1ISO40	CSMB2ISO40	CSMB3ISO40	CSMB4ISO40
63A	CSMB1ISO63	CSMB2ISO63	CSMB3ISO63	CSMB4ISO63
80A	CSMB1ISO80	CSMB2ISO80	CSMB3ISO80	CSMB4ISO80
100A	CSMB1ISO100	CSMB2ISO100	CSMB3ISO100	CSMB4ISO100
125A	CSMB1ISO125	CSMB2ISO125	CSMB3ISO125	CSMB4ISO125

NEW

CHANGE OVER SWITCHES

Rated Insulation Voltage Ui: 660V
 Rated Impulse Voltage Uimp: 4kV
 Mechanical / Electrical Life:
 15000/10000 Operations
 Terminal Capacity: 16mm²
 Front Operating with 3 Positions: 1, 0, 2
 Double Break Contacts
 Compact Design



CSCOS2P25A

Amps	2 Pole Code 2M Wide	4 Pole Code 4M Wide
25A	CSCOS2P25A	CSCOS4P25A
40A	CSCOS2P40A	CSCOS4P40A
63A	CSCOS2P63A	CSCOS4P63A

ACCESSORIES FOR 6 & 10kA MCB



CSMBS012SF



CSMBAXSF



CSMALSFW2

Code	Type	Voltage	Amps	Width
CSMBAXSF	Auxilliary Contact Left Side 1NO or 1NC	-	6A	½M
CSMBAXSF2	Auxilliary Contact Left Side 2NO or 2NC	-	6A	½M
CSMALSFW2	Alarm Contact Left Side	-	1A	½M
CSMBS012SF	Shunt Trip Right Side	12VDC	-	1M
CSMBS024SF	Shunt Trip Right Side	24VDC	-	1M
CSMBS048SF	Shunt Trip Right Side	48VDC	-	1M
CSMBS110SF	Shunt Trip Right Side	110VAC	-	1M
CSMBS220SF	Shunt Trip Right Side	220VAC	-	1M

CIRCUIT BREAKERS, FUSES & SWITCHGEAR

SMART ELECTRICAL DISTRIBUTION SYSTEM

Features

- Smart power management for home or commercial properties.
- Real-Time consumption alarms and safety information.
- Historical consumption data for up to 12 months (consumption, voltage and current fluctuations, load fluctuations).
- Remote control of specific circuits or the entire installation.
- Over & Under voltage alarms & over voltage protection.
- Arc Fault Alarm built in.
- Over temperature protection and alarms.

A basic system must be made up of the following modules:

- Power supply x1
- Communication module x1
- Circuit breakers (Depending on application)
- RCBO (Earth leakage Protection) x1



App: Matismart
Phone not included

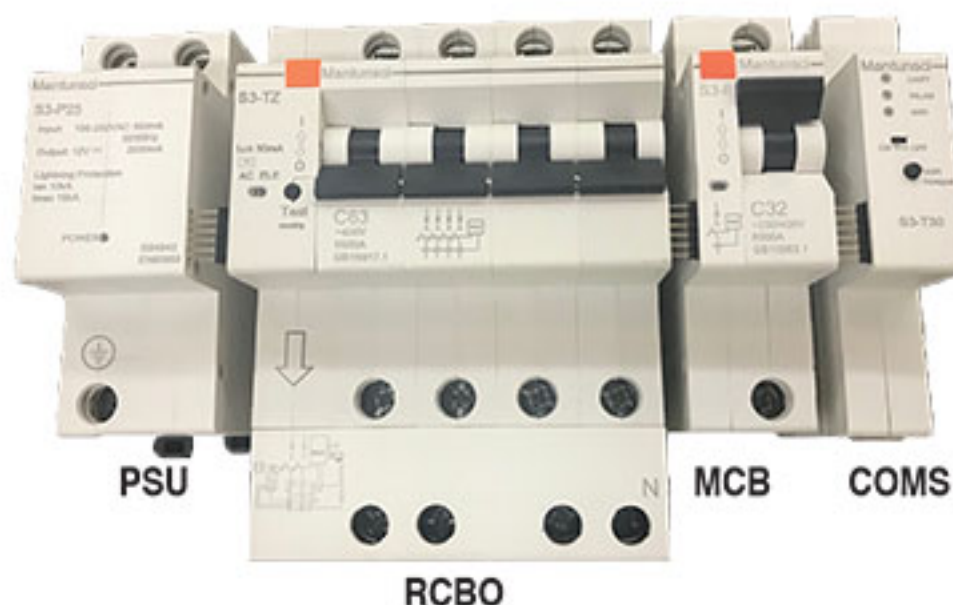

MT76-M20/1P



MT76-M63/3P



MT76-T30

MT76-P25

6kA Motorized Circuit Breaker C Curve (Din Modules 1M = 17.5mm)

Amps	1 Pole Code 1.5M Wide	2 Pole Code 2.5M Wide	3 Pole Code 4M Wide	4 Pole Code 5M Wide
10A	MT76-M10/1P	-	-	-
20A	MT76-M20/1P	-	-	-
32A	MT76-M32/1P	MT76-M32/2P	MT76-M32/3P	MT76-M32/4P
63A	MT76-M63/1P	MT76-M63/2P	MT76-M63/3P	MT76-M63/4P
80A	MT76-M80/1P	MT76-M80/2P	MT76-M80/3P	MT76-M80/4P

6kA Earth Leakage Relay With Overload Protection RCBO - 30mA

Amps	2 Pole Code 3M Wide	4 Pole Code 5M Wide
32A	MT76-L32	MT76-L32
63A	MT76-L63	MT76-L63
80A	MT76-L80	MT76-L80

Communication Modules

Code	Description
MT76-T30	Ethernet Gateway, WIFI or Wired Networks

Power Supply Module c/w Surge Protection

Code	Input	Output Voltage	Output Current	In	I _{max}
MT76-P25	100-260VAC	12VDC	2,5A	10kA	15kA

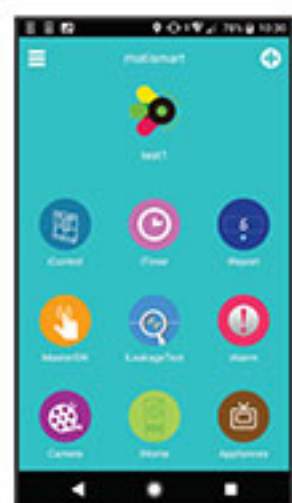

Matismart App home screen. iTimer allows custom on/off schedules to be set for applications like pool pumps and geysers.



View the status of a smart circuit breaker including temperature, current, voltage, power and leakage current (for RCBO). Switch the device on or off remotely and set power or current limits.

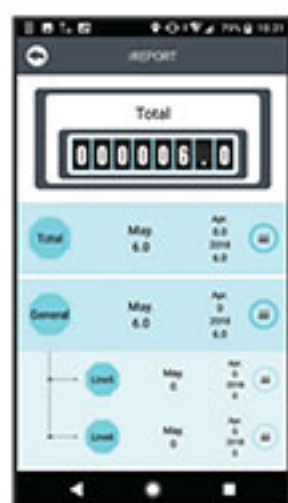

View current and historical consumption data in text or graphical format by Day / Week / Month.

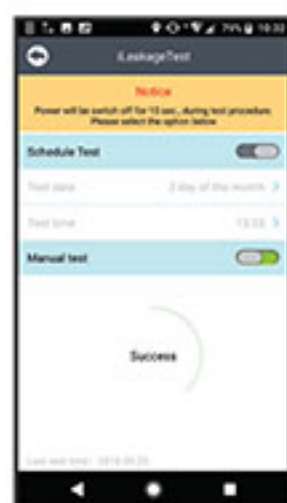

Do a remote earthleakage test or schedule the unit to test and report automatically at set times.

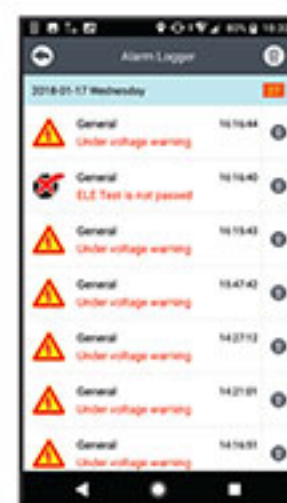

View a log of all alarms and status reports.



Master switch to power down an entire installation.

MODULAR CHANGEOVER SWITCHES & DIN CONTACTORS



SF2P-25A/40A

SF3P-25A/40A

SF4P-25A/40A

Modular Changeover Switches

Code	Amps AC22	No. of Poles	Width
SF2P-*	25, 40A	2P	2m
SF2P-*	63, 100, 125A	2P	4m
SF3P-*	25, 40A	3P	3m
SF3P-*	63, 100, 125A	3P	6m
SF4P-*	25, 40A	4P	4m
SF4P-*	63, 100, 125A	4P	8m

*Add amps to code: 25A, 40A, 63A, 100A, 125A



SF2P-63A/100A/125A

SF3P-63A/100A/125A

SF4P-63A/100A/125A

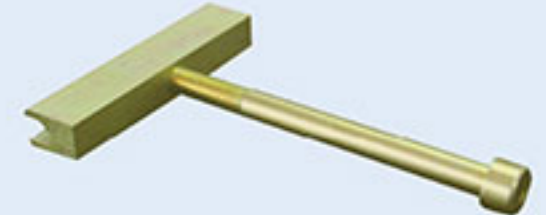

Code	Description
SFP-OH	Operating Handle for 63-125A



NCH8-20

TM2P-40A

TM4P-40A

DIN Contactors - Coil Voltage 230VAC

Code	Amps AC1	No. of Poles	Width
NCH8-20	12A	2P N/O	1m
TM2P- <i>A</i>	25A, 40A, 63A	2P N/O	2m
TM3P- <i>A</i>	25A, 40A, 63A	3P N/O	3m
TM4P- <i>A</i>	25A, 40A, 63A	4P N/O	3m
TM4P-25A/22	25A	2 N/O + 2 N/C	3m
TM4P-40A/22	40A	2 N/O + 2 N/C	3m
TM4P-63A/22	63A	2 N/O + 2 N/C	3m

*Add amps to code: 25, 40, 63

READY BOARDS



RB-1

RB-2/RB-2A

Ready Board RB-1

- 3 x 15A switched socket outlets
- 1 x 63A DP earth leakage
- 2 x 20A SP CB for socket outlets

Ready Board RB-2/2A

- 3 x 15A switched socket outlets
- 1 x 40 / 63A DP earth leakage
- 1 x 10A SP CB for lights
- 2 x 20A SP CB for socket outlets

Code	Size - H x W x D	Description
RB-1	330 x 245 x 90	No Bulkhead with 63A DP earth leakage
RB-2	455 x 245 x 90	With Bulkhead no lamp with 40A DP earth leakage
RB-2A	455 x 245 x 90	With Bulkhead no lamp with 63A DP earth leakage
NEW RB-2B	455 x 245 x 90	RB-2A with 2 x 16A SA sockets + 1 x 16A N-Type socket

MINIATURE CIRCUIT BREAKERS

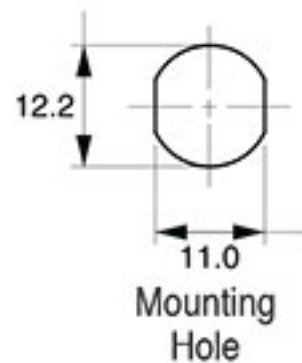

Mounting Hole

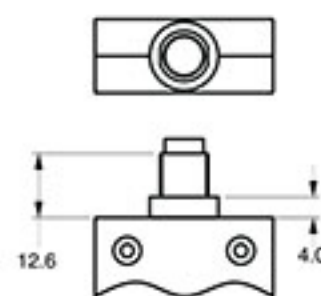
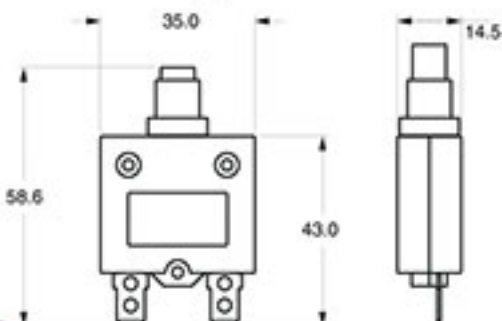

Manual Push Reset Thermal Circuit Breakers

Code	Amps (In)	Derating Factor	
A-0709U 4A	4A	0°C	In x 1.5
A-0709U 5A	5A	10°C	In x 1.3
A-0709U 6A	6A	15°C	In x 1.2
A-0709U 7A	7A	20°C	In x 1.1
A-0709U 8A	8A	25°C	In x 1
A-0709U 10A	10A	35°C	In x 0.85
A-0709U 12A	12A	40°C	In x 0.8
A-0709U 15A	15A	60°C	In x 0.6

125-250VAC/32VDC rated. 2,5kA@32VDC

Calibration of rated current @ 25°C:100%, Continuous

150%, Trip within 60 mins

200%, Trip within 40 secs

NEW

DIN MINIATURE CIRCUIT BREAKERS

C & D Curve 4,5kA Circuit Breakers

DIN Modules 1M = 17.5mm - IEC 60947-2 / VC8036



1 Pole C-Curve 1 Pole D-Curve 1 Pole + N



2 Pole C-Curve 2 Pole D-Curve



3 Pole C-Curve 3 Pole D-Curve



4 Pole C-Curve 4 Pole D-Curve

Amps	1 Pole Code 1M wide	1 P+N Code 1M wide	2 Pole Code 2M wide	3 Pole Code 3M wide	4 Pole Code 4M wide
1A	GYM8-1-1*	-	-	-	-
2A	GYM8-1-2*	-	GYM8-2-2*	GYM8-3-2*	GYM8-4-2*
3A	GYM8-1-3*	-	-	-	-
4A	GYM8-1-4*	-	-	-	-
6A	GYM8-1-6*	GYM8-1N-6*	GYM8-2-6*	GYM8-3-6*	GYM8-4-6*
10A	GYM8-1-10*	GYM8-1N-10*	GYM8-2-10*	GYM8-3-10*	GYM8-4-10*
16A	GYM8-1-16*	GYM8-1N-16*	GYM8-2-16*	GYM8-3-16*	GYM8-4-16*
20A	GYM8-1-20*	GYM8-1N-20*	GYM8-2-20*	GYM8-3-20*	GYM8-4-20*
25A	GYM8-1-25*	GYM8-1N-25*	GYM8-2-25*	GYM8-3-25*	GYM8-4-25*
32A	GYM8-1-32*	GYM8-1N-32*	GYM8-2-32*	GYM8-3-32*	GYM8-4-32*
40A	GYM8-1-40*	GYM8-1N-40*	GYM8-2-40*	GYM8-3-40*	GYM8-4-40*
50A	GYM8-1-50*	GYM8-1N-50*	GYM8-2-50*	GYM8-3-50*	GYM8-4-50*
63A	GYM8-1-63*	GYM8-1N-63*	GYM8-2-63*	GYM8-3-63*	GYM8-4-63*

*Add curve to code: **C** (C-Curve) or **D** (D-Curve)

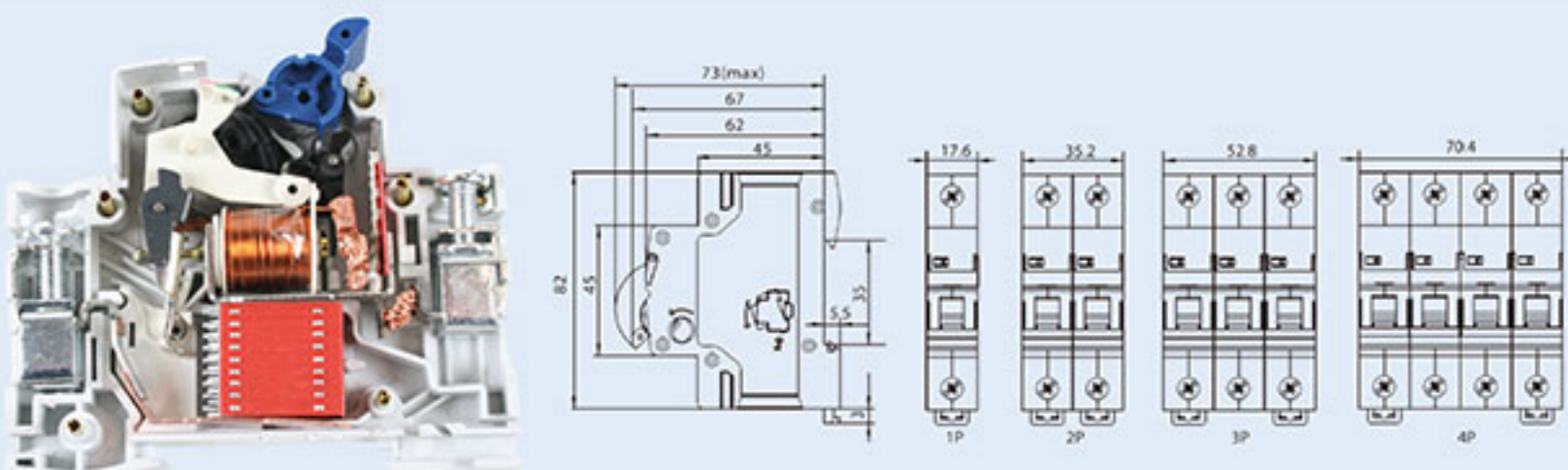

C & D Curve 10kA Circuit Breakers - IEC 60947-2 / VC8036



1 Pole C-Curve 1 Pole D-Curve

Amps	1 Pole Code 1.5M	1 P+N Code 3M	2 Pole Code 3M	3 Pole Code 4.5M	4 Pole Code 6M
80A	GYM16-1-80*	GYM16-1N-80*	GYM16-2-80*	GYM16-3-80*	GYM16-4-80*
100A	GYM16-1-100*	GYM16-1N-100*	GYM16-2-100*	GYM16-3-100*	GYM16-4-100*
125A	GYM16-1-125*	GYM16-1N-125*	GYM16-2-125*	GYM16-3-125*	GYM16-4-125*

*Add curve to code: **C** (C-Curve) or **D** (D-Curve)

Isolators - IEC 60947-3



Amps	1 Pole Code 1M wide	1 P+N Code 2M wide	2 Pole Code 2M wide	3 Pole Code 3M wide	4 Pole Code 4M wide
32A	GYH8-1-32	-	GYH8-2-32	GYH8-3-32	GYH8-4-32
63A	GYH8-1-63	-	GYH8-2-63	GYH8-3-63	GYH8-4-63
100A	GYH8-1-100	-	GYH8-2-100	GYH8-3-100	GYH8-4-100
125A	GYH8-1-125	-	GYH8-2-125	GYH8-3-125	GYH8-4-125

Earth Leakage Relays - 30mA VC8035



2 Pole 2 Pole 4 Pole

No Overload Protection			With Overload Protection		
Amps	2 Pole Code 1M Wide	2 Pole Code 2M Wide	4 Pole Code 4M Wide	Amps	2 Pole Code 2M Wide
32A	GYL8-1-32	-	-	-	-
25A	-	GYL8-2-25	GYL8-4-25	25A	GYR-8NM2-25
40A	-	GYL8-2-40	GYL8-4-40	32A	GYR-8NM2-40
63A	-	GYL8-2-63	GYL8-4-63	63A	GYR-8NM2-63

NEW

DIN MINIATURE CIRCUIT BREAKERS



Modular Accessories

Code	Type	Voltage	Amps	Width
GY-AU8*	Auxiliary Contact *1NO or 1NC	-	6A	½m
GY-AL8*	Alarm Contact *1NO or 1NC	-	1A	½m
GY-SH8	Shunt Trip Left Side	110-220VAC/DC	-	1m
GY-UV8	Undervoltage Relay Left Side	230VAC	-	1m

DIN MCB Accessories



Code	End Caps	Description	Carton Qty
------	----------	-------------	------------

Busbars – Spade Terminals

AS-25-SN	-	Busbar terminal for wire sizes up to 25mm²	-
S1L-1000/16	-	Insulated busbar 1 phase 63Amps, 1000mm, 56 poles	50
S2L-1000/16	EK-B-2+3	Insulated busbar 2 phase 63Amps, 1000mm, 56 poles	20
S3L-1000/16	EK-B-2+3	Insulated busbar 3 phase 63Amps, 1000mm, 56 poles	20
CK-SAM	-	Conversion Kit from DIN Breakers to 13mm mini rail	-
SP-FBD1M	-	1 x Module Rail Mount Dummy Dark Grey	-
SP-FBD1M-WH	-	1 x Module Rail Mount Dummy White	-
CK-SAM-R	-	1m Conversion rail din to 13mm mini rail - c/w Blanking Strip	-

Code	Description
------	-------------

Busbars – Fork Terminals

EK-B-2+3	Insulated end cap for 2 & 3 pole busbars
G1L-1000/16	Fork busbar 1 phase 63Amps, 1000mm, 56 poles.
G2L-1000/16	Fork busbar 2 phase 63Amps, 1000mm, 56 poles.
G3L-1000/16	Fork busbar 3 phase 63Amps, 1000mm, 56 poles.

NEW

PROJECT PACKS

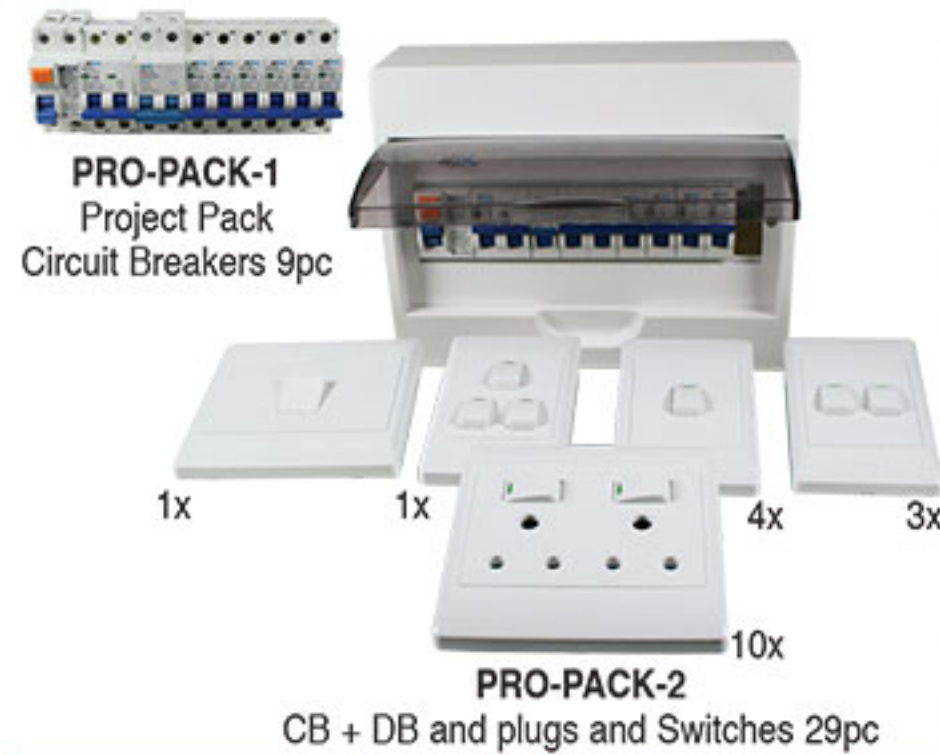

DIN Project Packs		
PRO-PACK-1	PRO-PACK-2	Item Description
x1	x1	63A 30mA 2P DIN RCD No Overload
x2	x2	10A 1P 4,5KA C Curve DIN Breaker
x3	x3	20A 1P 4,5KA C Curve DIN Breaker
x1	x1	40A 1P 4,5KA C Curve DIN Breaker
x1	x1	63A 2P 4,5KA C Curve DIN Breaker
x1	x1	32A 1P+N 4,5KA C Curve DIN Breaker
-	x1	White 12-Way Surface DIN DB
-	x4	1-Lever 1-Way Switch 2x4
-	x3	2-Lever 1-Way Switch 2x4
-	x1	3-Lever 1-Way Switch 2x4
-	x10	2 x 16A Switched Socket Outlet 4x4 Cover
-	x1	45A DP Stove Isolator 4x4

DIN PRE-ASSEMBLED DISTRIBUTION BOARDS



White Pre-assembled Distribution Boards - Populated with 4.5kA AC/DC Breakers						
Surface	Pre-Wired		12 Way Pre-Wired		12 Way Pre Assembled	
	8 Way DB	12 Way DB	Code	SRB-4	Code	SRB-5
Surface	SRB-3	SRB-3/12				
	Pre-Wired		12 Way Pre-Wired		12 Way Pre Assembled	
Flush	8 Way DB	12 Way DB	Code	FRB-4	Code	FRB-5
	FRB-3	FRB-3/12				
Surface Type		• Smokey, transparent lid	Flush Type		• 20mm and 25mm knock outs	
• Adjustable steel tray		• 2 x Neutral bars, fitted,	• 20mm and 25mm knock outs		• 2 x Neutral bars, fitted,	
• 20mm and 25mm knock outs		• 1 x Earth bar	• Smokey, transparent lid		• 1 x Earth bar	

CIRCUIT BREAKERS, FUSES & SWITCHGEAR

13MM MINIATURE CIRCUIT BREAKERS (MCBs) 4.5kA

SA Range 1M = 13mm IEC60947 / VC8036



1P C Curve 1P+N C Curve 3P D Curve



2P D Curve 4P C Curve



6kA C Curve ≥ 63A 6kA D Curve ≥ 63A



6kA 4P C Curve ≥ 63A

Amps	1 Pole Code 1M wide	1 P+N Code 2M wide	2 Pole Code 2M wide	3 Pole Code 3M wide	3 P+N Code 4M wide	4 Pole Code 4M wide
------	------------------------	-----------------------	------------------------	------------------------	-----------------------	------------------------

4.5kA Circuit Breakers C Curve

1A	SA1-1	-	-	-	-	-
2A	SA1-2	-	-	-	-	-
5A	SA1-5*	SA1N-5*	SA2-5*	SA3-5*	SA3N-5	SA4-5
10A	SA1-10*	SA1N-10*	SA2-10*	SA3-10*	SA3N-10	SA4-10
15A	SA1-15*	SA1N-15*	SA2-15*	SA3-15*	SA3N-15	SA4-15
20A	SA1-20*	SA1N-20*	SA2-20*	SA3-20*	SA3N-20	SA4-20
25A	SA1-25*	SA1N-25*	SA2-25*	SA3-25*	SA3N-25	SA4-25
32A	SA1-32*	SA1N-32*	SA2-32*	SA3-32*	SA3N-32	SA4-32
40A	SA1-40*	SA1N-40*	SA2-40*	SA3-40*	SA3N-40	SA4-40
50A	SA1-50*	SA1N-50*	SA2-50*	SA3-50*	SA3N-50	SA4-50
63A	SA1-63*	SA1N-63*	SA2-63*	SA3-63*	-	SA4-63

6kA Circuit Breakers C Curve

5A	SA61-5*	-	SA62-5*	SA63-5*	-	-
10A	SA61-10*	-	SA62-10*	SA63-10*	-	-
15A	SA61-15*	-	SA62-15*	SA63-15*	-	-
20A	SA61-20*	-	SA62-20*	SA63-20*	-	-
25A	SA61-25*	-	SA62-25*	SA63-25*	-	-
32A	SA61-32*	-	SA62-32*	SA63-32*	-	-
45A	SA61-40*	-	SA62-40*	SA63-40*	-	-
50A	SA61-50*	-	SA62-50*	SA63-50*	-	-

Amps	1 Pole Code 2M wide	-	2 Pole Code 4M wide	3 Pole Code 6M wide	-	4 Pole Code 8M wide
63A	SA61-63*	-	SA62-63*	SA63-63*	-	SA64-63
80A	SA61-80*	-	SA62-80*	SA63-80*	-	SA64-80
100A	SA61-100*	-	SA62-100*	SA63-100*	-	SA64-100
125A	SA61-125*	-	SA62-125*	SA63-125*	-	SA64-125

* For D Curve Breakers, Add -D to code, e.g. SA1-10-D

Isolators



Amps	1M wide	-	2M wide	3M wide	-	4M wide
25A	SAS1-25	-	SAS2-25	SAS3-25	-	SAS4-25
40A	SAS1-40	-	SAS2-40	SAS3-40	-	SAS4-40
63A	SAS1-63	-	SAS2-63	SAS3-63	-	SAS4-63

Earth Leakage Relays - RCDs 30mA



No Overload Protection					With Overload		
Amps	2 Pole Code	Width	4 Pole Code	Width	Amps	2 Pole Code	Width
25A	SAE2-25	2M	SAE4-25	4M	25A	SAE2L-25	2M
40A	SAE2-40	2M	SAE4-40	4M	32A	SAE2L-32	2M
63A	SAE2-63	2M	SAE4-63	4M	63A	SAE2L-63	2M

Surge Protection Device



Code	Class	No. of poles	I _{max} 8/20	I _n 8/20	U _p	U _c	U _n	Width
SASP-5KA	2	1	10kA	5kA	1200V	275V	230V	1M
SASP-15KA	2	1	30kA	15kA	1200V	275V	230V	1M

Time Switch



Code	Description
SAT-30A	<ul style="list-style-type: none"> • 24hrs/7days 8 On + 8 Off Programs • 3M Width (39mm) • Switching Capacity: 30A • 15 Days Reserve

13MM MINIATURE CIRCUIT BREAKERS (MCBs) 4.5kA

13mm Mini C/B Accessories	
Code	Description
SAM-RAIL	Mini Rail for circuit breakers 77 Way/1m
SAM-B1C	Copper busbar for 13mm mini rail breakers 750mm long 1 Pole black insulated
SAM-B1	Copper busbar for 13mm mini rail breakers 750mm long 1 Pole non-insulated
SAM-B2C	Copper busbar for 13mm Mini Rail Breakers 750mm long 2 Pole black insulated
SAM-B3C	Copper busbar for 13mm mini rail breakers 750mm long 3 Pole black insulated
SAM-BLANK-WH	4½ way 13mm mini rail blanks, white
SAM-BLANK-BK	4½ Way 13mm mini rail blanks, black
SAM-NB	Neutral bar clip-in to rail Accommodates 16mm² x 1, 7mm² x 7

Arc chute has 13 splitter plates to increase safety and extend contact life

Thermal magnetic tripping mechanism provides accurate tripping at lower currents and protects against loose connection on the load terminals

MCB Isolator Earth Leakage

Flush Mount

Surface Mount

Dual rail mounting: Mini Rail or DIN Rail

NEW PROJECT PACKS

13mm Mini Rail Project Packs		
PRO-PACK-SA1	PRO-PACK-SA2	Description
x1	x1	63A 30mA 2P Mini Rail RCD No Overload
x2	x2	10A 1P 4,5KA C Curve Mini Rail Breaker
x3	x3	20A 1P 4,5KA C Curve Mini Rail Breaker
x1	x1	40A 1P 4,5KA C Curve Mini Rail Breaker
x1	x1	63A 2P 4,5KA C Curve Mini Rail Breaker
x1	x1	32A 1P+N 4,5KA C Curve Mini Rail Breaker
-	x1	White 16-Way Surface Mini Rail DB
-	x4	1-Lever 1-Way Switch 2x4
-	x3	2-Lever 1-Way Switch 2x4
-	x1	3-Lever 1-Way Switch 2x4
-	x10	2 x 16A Switched Socket Outlet 4x4
-	x1	45A DP Stove Isolator 4x4

13MM PRE-WIRED DISTRIBUTION BOARDS

Flush Type	White Pre-Assembled Distribution Boards - Populated with 13mm MCBs				Surface Type
	8 Way		11 Way		
	Pre-Wired	Pre-Assembled	Pre-Wired	Pre-Assembled	
Surface	SRBSAM-3	SRBSAM-5	SRBSAM-4	SRBSAM-6	<ul style="list-style-type: none"> • 20mm & 25mm knock outs • Smokey, transparent lid • 2x Neutral bars, fitted • 1x Earth bar
Flush	FRBSAM-3	FRBSAM-5	FRBSAM-4	FRBSAM-6	
	1x 63A 1P+N MCB (Mains)		1x 63A 1P+N MCB (Mains)		
	1x 32A SP MCB (Stove)		1x 32A SP MCB (Stove)		
	1x 16A SP MCB (Geyser)		1x 16A SP MCB (Geyser)		
	1x 63A ELU 30mA		1x 63A ELU 30mA		
	1x 10A SP MCB (Lights)		2x 10A SP MCB (Lights)		
	1x 20A SP MCB (Plugs)		3x 20A SP MCB (Plugs)		
	Supplied in 11-way enclosure.				

CIRCUIT BREAKERS, FUSES & SWITCHGEAR

NEW

DC FUSES & FUSE HOLDERS

Photovoltaic Fuses - 10 x 38mm - gPV

Rated Voltage:
1000V
Breaking Capacity:
20kA



Photovoltaic Fuses - 14 x 51mm - gPV

Rated Voltage:
1000V
Breaking Capacity:
20kA



Photovoltaic Fuses - 10 x 85mm - gPV

Rated Voltage:
1500V
Breaking Capacity:
20kA



Code	Rated Current	Code	Rated Current	Code	Rated Current	Code	Rated Current
30F1PV	1A	30F8PV	8A	30F15PV-L	15A	F1085GPV-2	2A
30F2PV	2A	30F10PV	10A	30F20PV-L	20A	F1085GPV-4	4A
30F3PV	3A	30F12PV	12A	30F25PV	25A	F1085GPV-10	10A
30F4PV	4A	30F15PV	15A	30F32PV	32A	F1085GPV-16	16A
30F5PV	5A	30F20PV	20A			F1085GPV-20	20A
30F6PV	6A					F1085GPV-30	30A

10 x 38mm DIN Fuse Base - 1000VDC



14 x 51mm DIN Fuse Base - 1000VDC



10 x 85mm DIN Fuse Base - 1500VDC



Code	Ratings	Code	Ratings	Code	Ratings
SRD-30	1000VDC, 30A	SRD-63	1000VDC, 50A	SRD-32L	1500VDC, 30A

NH Photovoltaic Fuses - gPV



Rated Voltage: 1000V
Breaking Capacity: 50kA (Size 1)
30kA (Size 2XL)

Code	Rated Current	DIN Fuse Size
NH1GPV-32	32A	1
NH1GPV-40	40A	1
NH1GPV-50	50A	1
NH1GPV-63	63A	1
NH1GPV-80	80A	1
NH1GPV-100	100A	1
NH1GPV-125	125A	1
NH1GPV-160	160A	1
NH2XLGPV-200A	200A	2XL
NH2XLGPV-250A	250A	2XL
NH2XLGPV-315A	315A	2XL
NH2XLGPV-350A	350A	2XL
NH2XLGPV-400A	400A	2XL

1000VDC NH Fuse Bases



Code	NH1PVB	NH2XLB
Ratings	Size 1 1000VDC, 250A	Size 2XL 1000V, 400A

NEW

1000VDC FUSEHOLDERS

Gaue

Fuse Holders for DC Applications

Code	Thermal Rating	Fuse Size	Poles	Width
211PV	20A	10 x 38	1 Pole	18mm
221PV	50A	14 x 51	1 Pole	27mm

Accessories

Code	Description
21KE	Multipole assembly kits

According To

- IEC 60947-1
- IEC 60947-3

Characteristics

- 1000VDC - DC-20B
- Mounting 35mm DIN rail
- High temperature resistant plastics
- Elevated insulation characteristics

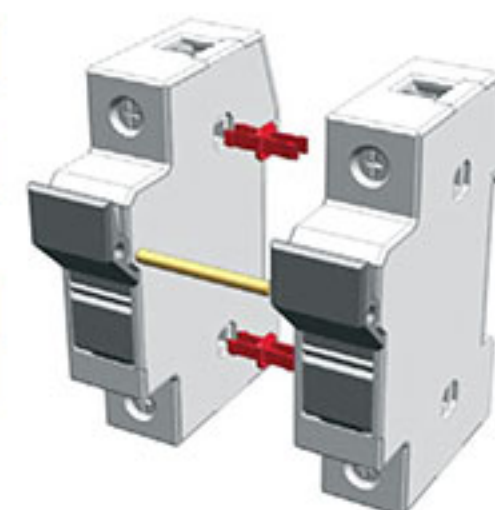

For multipole fuse holders use multipole assembly kits - 21KE

NEW BUSBAR DISTRIBUTION SYSTEM

Busbar Power Distribution Systems for use in Panels

- Electrical Components are mounted directly onto the busbars
- Fast & Easy Installation
- No Drilling Required
- Easily Expandable
- Space Saving Design

Application Examples

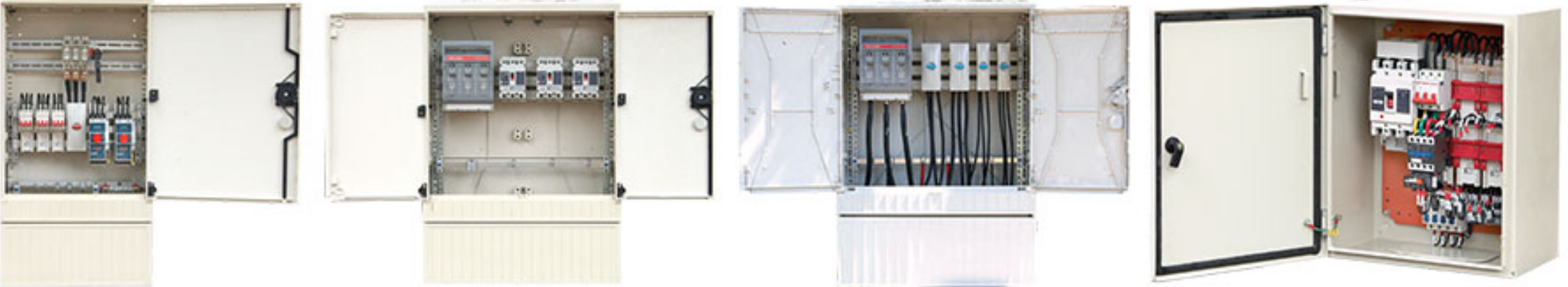

Tin plated Copper Busbar

Code	Busbar Size	Length	Cross Section	Current
DN51618	12 x 5	2400mm	60mm ²	200A
DN51381	12 x 5	790mm	60mm ²	200A
DN51382	12 x 5	590mm	60mm ²	200A
DN51619	20 x 5	2400mm	100mm ²	320A
DN51383	20 x 5	790mm	100mm ²	320A
DN51384	20 x 5	590mm	100mm ²	320A
DN51622	30 x 5	2400mm	150mm ²	450A
DN51387	30 x 5	790mm	150mm ²	450A
DN51388	30 x 5	590mm	150mm ²	450A
DN51624	20 x 10	2400mm	200mm ²	520A
DN51391	20 x 10	790mm	200mm ²	520A
DN51392	20 x 10	590mm	200mm ²	520A
DN51625	30 x 10	2400mm	300mm ²	630A
DN51393	30 x 10	790mm	300mm ²	630A
DN51394	30 x 10	590mm	300mm ²	630A

Busbar Supports

Support Code	End Cover Code	Busbar Spacing	Poles	Busbar Size (mm)
DN52001	DN53230	185mm	3P	30 x 5
DN52230	DN53230	185mm	3P	30 x 10
DN52500	DN53573	60mm	3P	12 / 20 / 30 x 10
DN52005	DN53573	60mm	3P	12 / 20 / 30 x 5
DN52356	-	60mm	2P	12 / 20 / 30 x 5 / 10
DN52601	-	-	1P	12 / 20 / 30 x 5 / 10
DN52357	DN53131	60mm	4P	12 / 20 / 30 x 5 / 10

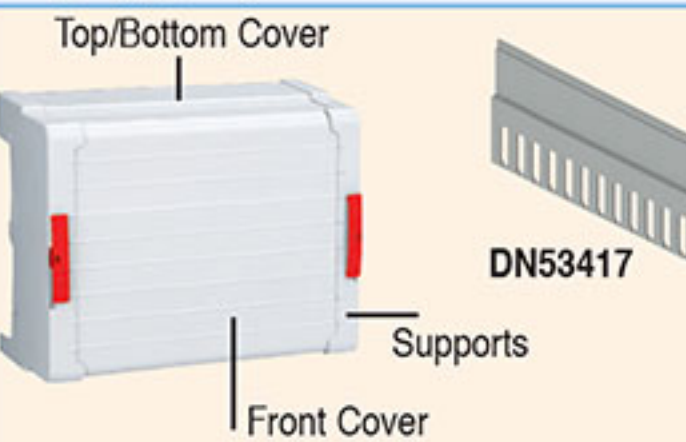

System Covers - For 60mm System

Code	Poles	Description
DN53136	3	Left & Right Support
DN53137	4	Left & Right Support
DN53555	-	1100mm Top/Bottom Cover Solid
DN53417	-	1100mm Top/Bottom Cover Slotted
DN53554	3	1100mm Front Cover
DN53599	4	1100mm FrontCover

Clip-on Covers - For Individual Busbars

Code	Busbar Size (mm)
DN53244	12-30 x 5
DN53245	12-30 x 10



DN53245



Multi-Pole In/Output Connection Modules - Cable / Busbar to Busbar System Connection

Support Code	Busbar Spacing	Poles	Max Current	Busbar Size (mm)	Terminal Capacity
DN54563	60mm	3P	80A	12 / 20 / 30 x 5 / 10	1.6-16mm ²
DN54240	60mm	3P	300A	12 / 20 / 30 x 5 / 10	6-50mm ²
DN54243	60mm	3P	440A	12 / 20 / 30 x 5 / 10	35-120mm (Max)
DN54753	60mm	3P	630A	20 / 30 x 5 / 10	Laminated Busbar 30 x 20mm ²
DN54199	60mm	3P	460A	20 / 30 x 5 / 10	95-185mm ²
DN54754	60mm	3P	560A	20 / 30 x 5 / 10	120-300mm ²
DN54147	60mm	4P	560A	20 / 30 x 5 / 10	120-300mm ²
DN54162	60mm	4P	630A	20 / 30 x 5 / 10	Rectangle Busbar 30 x 20mm Max
DN54185	185mm	3P	400A	12 / 20 / 30 x 5 / 10	120-240mm ²
DN54186	185mm	3P	630A	12 / 20 / 30 x 5 / 10	150-300mm ²

BUSBAR DISTRIBUTION SYSTEM

NEW

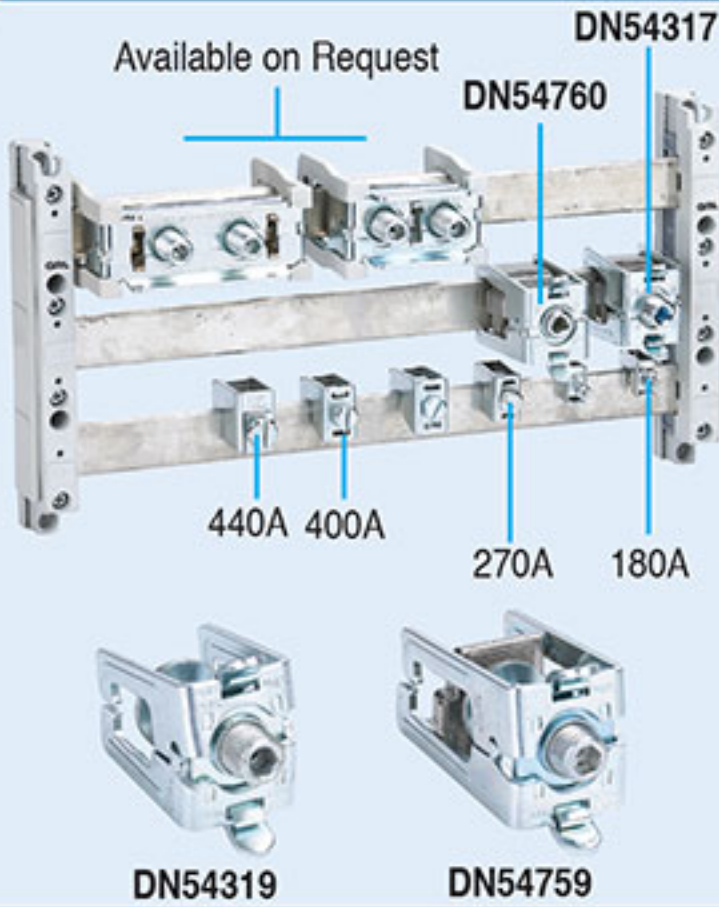

Universal 1Pole busbar connectors - Connection of In/Output Cables/Busbars to busbars

Code	Current	Connect to Busbar	Terminal Capacity
DN54284	180A	12 / 20 / 30 x 5mm	1.5-16mm ²
DN54285	270A	12 / 20 / 30 x 5mm	4-35mm ²
DN54287	400A	12 / 20 / 30 x 5mm	16-70mm ²
DN54068	440A	12 / 20 / 30 x 5mm	16-120mm ²
DN54289	180A	12 / 20 / 30 x 10mm	1.5-16mm ²
DN54290	270A	12 / 20 / 30 x 10mm	4-35mm ²
DN54292	400A	12 / 20 / 30 x 10mm	16-70mm ²
DN54203	440A	12 / 20 / 30 x 10mm	16-120mm ²
DN54317	500A	20 / 30 x 5 / 10mm	95-185mm ²
DN54760	600A	20 / 30 x 5 / 10mm	120-300mm ²
DN54319	750A	20 / 30 x 5 / 10mm	30 x 20mm ² (Max) Busbar
DN54759	800A	20 / 30 x 5 / 10mm	30 x 20mm ² (Max) Busbar



Busbar Mount Base Plates for Moulded Case Circuit Breakers - 60mm System

Base Code	Connecting Busbar*	Tembreak Frame Size	Rated Current	Poles
DN55177*	DN28000	160A TB Lite	16-160A	3P
DN55037*	DN28001	160/250A TB2 / 250A TB Lite	200-250A	3P
DN55023*	DN28002 (400A), DN28003 (580A)	400/630A TB2	250A - 580A	3P

*Flexible busbar connector to be ordered separately. Order 3pcs. Breakers available on page 199-200



Busbar Mount Base Plates for Miniature Circuit Breakers and Switchgear - 60mm System

Code	Current	DIN Rails	Dimensions W x L
DN55300	80A	1	54 x 200mm
DN55325	80A	2	54 x 200mm
DN55301	80A	1	54 x 260mm
DN55326	80A	2	54 x 260mm
DN55310	80A	1	81 x 200mm
DN55335	80A	2	81 x 200mm
DN55313	80A	1	81 x 260mm
DN55338	80A	2	81 x 260mm



Busbar Mounted 10x38 Fuse Switch - 60mm System

Code	Max Current	Rated Voltage	Poles
DN56017	32A	690VAC	3P
DN56021	32A	690VAC	3P+N
DN56023	32A	690VAC	2P
DN56024	32A	1000VDC	2P

Busbar Mounted 3P NH Fuse Switch - 60mm System

Base Mounted 3P Horizontal NH Fuse Switch



Code	Rated Voltage	Fuse Size	Rated Current	Code	Rated Voltage	Fuse Size	Rated Current
DN7-160/310	400VAC	00	160A	DN7-160/300	400VAC	00	160A
DN7-250/310	400VAC	1	250A	DN7-250/300	400VAC	1	250A
DN7-400/310	400VAC	2	400A	DN7-400/300	400VAC	2	400A
DN7-630/310	400VAC	3	630A	DN7-630/300	400VAC	3	630A

Busbar Mounted Vertical NH Fuse Disconnecter - 185mm System



Standard Code	Code c/w CT's	Fuse Size	Rated Current	Rated Voltage	Ui
DN18-160/3L	DN18-160/3L-A	00	160A	690VAC	1000V
DN18-250/3L	DN18-250/3L-A	1	250A	690VAC	1000V
DN18-400/3L	DN18-400/3L-A	2	400A	690VAC	1000V
DN18-630/3L	DN18-630/3L-A	3	630A	690VAC	1000V

c/w CT's & Ammeter Support

NH FUSE SWITCH DISCONNECTORS

NH Fuse Switch

Size 000:
DIN Rail/Base
Mounting
Size 00, 1, 2, 3:
Base mounting
Rated Voltage:
690VAC



Fuse size	000	00	1	2	3
1 Pole Code	-	G-711	G-731	-	-
3 Pole Code	G-703	G-713	G-733	G-743	G-753
4 Pole Code	-	G-714	G-734	-	-
Current Rating	Up to 100A	Up to 160A	Up to 250A	Up to 400A	Up to 630A

NH Fuse Switch Busbar Mount

Direct installation onto
60mm busbar systems
Using 5/10mm
Busbar width see page
207-208
Rated Voltage:
690VAC



Fuse size	00	1	2
3 Pole Code	G-713PC	G-733PC	G-743PC
Current Rating	Up to 160A	Up to 250A	Up to 400A

Easy direct installation by snapping onto the busbars.

Touch protection **IP20** - when fuse link is in test mode IP rating is maintained.

INDUSTRIAL FUSE HOLDERS

Fuse Holders

Rated Voltage: 690VAC

- High insulation voltage rating.
- Resistant to abnormal heat and fire
(Glow wire flammability test at 960 °C according to IEC 695-2-1).
- Elevated vibration withstand.



Fuse Size (mm)	10 x 38	14 x 51	22 x 58
1 Pole Code	G-211	G-221	G-231
2 Pole Code	G-212	G-222	G-232
3 Pole Code	G-213	G-223	G-233
3 P+N Code (c/w neutral link)	G-213N	G-223N	G-233N



Ergonomic Handle
Adapted shape for easy access and operation.

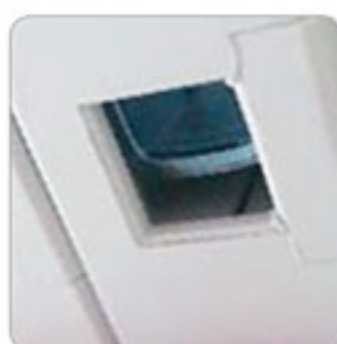

Protection Degree IP20
Protected against accidental finger contact.



Assembly Kits
Push in clips and pins for multipole assemblies.



Marking
Easy to identify. Reference and basic data visible on front handle. Electrical characteristics on the side.

Assembly Kit

Code	Description
21KE	Assembly kit for fuse holder (10x38) (14x5)
23KE	Assembly kit for fuse holder (22x58)



21KE / 23KE

CYLINDRICAL FUSES & HOLDERS

Cylindrical Fuses (500V) IEC269				1500V Fuses	Glass Fuses	Ceramic Fuses	Fast Blow
Size mm	10 x 38	14 x 51	22 x 58	10 x 85	5 x 20	5 x 20	6.3 x 32
AM type UF type					250V	250V	250V
GL Fuse	1038*	1451*	2258*	F602*	F600**	F700**	F601**
AM Fuse	AM1038*	AM1451*	AM2258*	*2A	*100mA *2A	*1A	*250mA *5A
Ultra Fast Fuse	UF1038*	UF1451*	UF2258*	*4A	*250mA *3A	*2A	*500mA *6.3A
Current *Add Amp to code Rated Voltage: 500V Breaking Capacity: 100kA	*01A *12A	*10A *32A	*10A *32A	*6.3A	*500mA *3.5A	*3A	*750mA *10A
	*02A *16A	*12A *40A	*12A *40A	*10A	*1A *4A	*4A	*800mA *15A
	*04A *20A	*16A *50A	*16A *50A	*16A	*1.25A *5A	*5A	*1A *16A
	*06A *25A	*20A *63A	*20A *63A		*1.5A *6.3A	*6.3A	*1.6A *20A
	*08A *32A	*25A	*25A *80A		*1.6A *10A	*10A	*2A *25A
	*10A		*100A		*15A	*15A	*3A *30A
					*20A	*20A	*4A
					5 Pack		5 Pack

Fuse Holders 690V



Size mm	10 x 38	14 x 51	22 x 58
Neutral link	1038.N	1451.N	2258.N
1 Pole	MSC1038.1	CMS1451.1	CMS2258.1
2 Pole	MSC1038.2	CMS1451.2	CMS2258.2
3 Pole	MSC1038.3	CMS1451.3	CMS2258.3
4 Pole	MSC1038.4	CMS1451.4	CMS2258.4
1 N Pole	MSC1038.N	CMS1451.N	VS2258.N

* Add quantity to Code /100, /5 eg F601 1.6A/5

Fuse Holders

P114 21.5mmØ 1000V	P115 12mmØ 250V	HF-015 12mmØ 250V	SP1120 (5x20) SP1132 (6.3x32) 250V	P113 15mmØ 250V
For Fuse 10 x 85 16A max.	5 x 20mm Panel Mount	5 x 20mm Panel Mount	Inline Fuse Holder	6.3 x 32mm Panel Mount

Econo Type Fuse Holders 500V | Panel Mount Fuse Holder | Open Type Fuse Holders | P.C.B. Fuse Holders | DIN Mount



Pole	Code w/o indication	Code with indication	Pole	Code	Specification	Pole	Code	Code	Pole
1 Pole	VS1038.1	LVS1038.1	1 Pole	P1891	Max. 30A 600V	1 Pole	FB1038.1	FS10	1 Pole
2 Pole	VS1038.2	LVS1038.2	1 Pole	P1892	Max. 30A 600V				
3 Pole	VS1038.3	LVS1038.3							
1 N Pole	VS1038.N	-							

DIN HRC FUSE LINKS AND CARRIERS

Standard Protection Fuses with Indicator	DIN Size	C00	00	0	1	2	3
<p>Current *Add Amp to code Rated Voltage: 500V Fault Capacity: 120kA</p>	Code GL	24700-*	24585-*	24710-*	24720-*	24582-*	24588-*
	*6A *35A	*100A	*125A	*200A	*200A	*400A	
	*10A *40A	*125A	*160A	*250A	*250A	*500A	
	*16A *50A	*160A			*315A	*630A	
	*20A *63A				*355A	*800A	
*25A *80A				*400A			
*32A *100A							
Semi Conductor Protection Ultra Fast Fuses							
Code Ultra Fast 500V DIN	UF24700-*	UF24585-*	UF24710-*	UF24720-*			NH-SW1
Code Ultra Fast 660V	UFB00-*	UFB00-*	UFB0-*	UFB1-*			
Current *Add Amp to code Fault Capacity: 120kA	*6A, *10A, *16A *20A, *25A, *32A *40A, *50A, *63A *80A, *100A	*100A *125A	*125A *160A	*125A *160A (UF Type) *200A *250A		S1000-80-00	Micro Switch for DIN Fuses size C00 to 3 for indica- tion of blown fuse
Neutral Link							
		NL24585	NL24585	NL24710	NL24720	NL24582	NL24588
IP00 Fuse Bases							
DIN Mount	1 Pole	CT-00FB	CT-00FB	CT-01FB	CT-01FB	CT-02FB	CT-03FB
	DIN Mount						
Fuse Handle 24649 fits all sizes	3 Pole	24645	24645	24646	24646	24647	-
Code	1 Pole	3 Pole	Terminal Cover	Fuse Cover	Fuse Barriers	Fuse Linking Piece	
Size C00 & 00	7900.N	7903.00	CT-00FBC1	CT-00FBC2	CT-00FBC3	-	
Size 0 & 1	7901.N	7903.01	CT-01FBC1	CT-01FBC2	CT-01FBC3	CT-01FBC4	
Size 2	7902.N	7903.02	CT-01FBC1	CT-01FBC2	CT-01FBC3	CT-01FBC4	
Size 3	7903.N	7903.03	CT-03FBC1	CT-03FBC2	-	CT-03FBC4	

SQUARE BODY TYPE B FUSES

COOPER Bussmann



Dimensions (mm)

Size	A	B	D	E	F	G	H
01	50	51	N/A	45	M8	5	17
1	50	51	69	N/A	M8	8	20
2	50	51	N/A	61	M10	10	24
3	51	53	N/A	76	M12	10	30

High Speed Fuse - Rated Voltage: 690VAC (IEC/UL)

• Characteristic: aR • Fault Capacity: 200kA

Size	Size 01	Size 1	Size 2	Size 3
Code	170M34-*	170M44-*	170M54-*	170M64-*
Current	*63A *80A *100A *125A *160A *200A *250A *315A *350A *400A *450A *500A *630A	*200A *250A *315A *350A *400A *450A *500A *550A *630A *700A *800A *900A *1000A *1100A *1250A *1400A *1500A *1600A	*400A *450A *500A *550A *630A *700A *800A *900A *1000A *1100A *1250A - - -	*500A *550A *630A *700A *800A *900A *1000A *1100A *1250A *1400A *1500A *1600A - - -

*Add Amp to code

BS ULTRA RAPID FUSE LINKS

Bussmann Ultra Rapid Fuses – 240V

Code	Rated Current RMS-Amps	I ² t (Amps ² secs)			Loss
		Pre-arc	Clearing at 120V	Clearing at 240V	
25LET	25A	18	120	250	4W
32LET	32A	32	200	450	5W
35LET	35A	50	320	600	5W
50LET	50A	100	500	1.4k	7W
63LET	63A	180	1.1k	2.2k	9W
80LET	80A	300	1.9k	3.8k	10W
100LET	100A	600	3.8k	7.5k	10W
125LET	125A	600	3.8k	7.5k	16W
160LET	160A	1.1k	7k	16k	20W
180LET	180A	1.6k	12k	29k	21W

Bussmann Ultra Rapid Fuses – 690V

Code	Rated Current RMS-Amps	I ² t (Amps ² secs)			Loss
		Pre-arc	Clearing at 415V	Clearing at 660V	
25ET	25A	25	150	250	7W
32ET	32A	32	190	350	11W
40ET	40A	103	600	900	9W
45ET	45A	103	680	1.1k	11W
56ET	56A	135	950	1.5k	14W
63ET	63A	171	1.2k	2k	16W
80ET	80A	360	2.5k	4k	18W
63FE	63A	135	480	750	12W
80FE	80A	250	900	1.5k	20W
90FE	90A	360	1.3k	2.1k	20W
100FE	100A	470	1.8k	2.8k	23W
110EET	110A	600	4k	6.5k	27W
140EET	140A	1050	7k	12k	35W

Dimensions Fuse Guide for SCRs: Fuse I²t ≤ 0.75 x SCR I²t

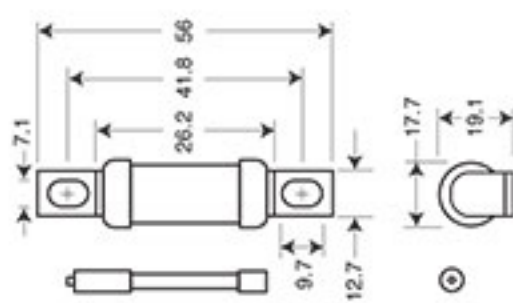

LET

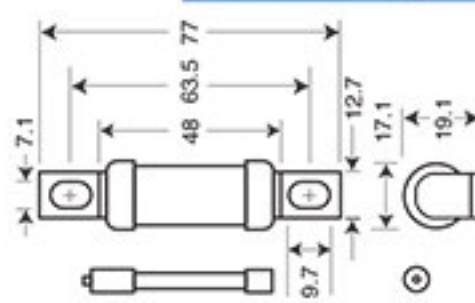

ET, FE

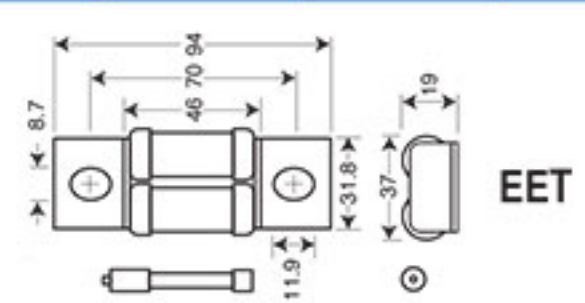

EET

J-TYPE POLE FUSES



Code	SMJ30-*	SPJ30-*	SMJ31-*	SPJ31-*
Fixing Centres	82mm	82mm	92mm	92mm
Fuse Body	Ø39mm	Ø50mm	Ø39mm	Ø50mm
Rated voltage: 415V Fault Capacity: 80kA	*20A *100A *32A *125A *40A *160A *50A *200A *63A *250A *80A *315A	*355A *400A	*20A *100A *32A *125A *40A *160A *50A *200A *63A *250A *80A *315A	*355A *400A

Slotted type fuses designed for wedge type fuse carriers on BS applications. For use by electrical authorities in distribution pillars, open type sub-station boards, heavy duty cutouts and underground connection boxes.

*Add current rating to code

PLUG TOP FUSE-LINKS

Rated Voltage: 240V
Breaking Capacity: 6kA

Cylindrical Fuses - Size: 6.45 x 24.4mm



Code	Rating	Colour Code
C180-13A	13A	Black

STOVE FUSES

Screw Capped (E27) Glass Fuses 240V



Code	Current Rating	Code	Current Rating
SF-E27-6A	6A	SF-E27-20A	20A
SF-E27-10A	10A	SF-E27-25A	25A
SF-E27-15A	15A	SF-E27-30A	30A

BS HRC FUSE LINKS & CARRIERS

BS 88 Size	NS	A1	A2	A3	A4	A5		
 Standard Protection IEC269 – BS88								
Code*	BNS*		BNIT*	BTIA*		BTIS*	BTCP*	BTFP*
Current (*Add Amp to code)	*2A	*16A	*2A	*2A	*20A	*35A	*63M80A	
	*4A	*20A	*4A	*4A	*25A	*40A	*63M100A	
	*6A	*25A	*6A	*6A	*32A	*50A	*100M200A	*125A
	*10A	*32A	*10A	*10A		*63A		*160A
			*16A	*16A				
			*20A					
Voltage AC	550V		550V	660V		660V	660V	660V
Fault capacity	80kA		80kA	80kA		80kA	80kA	80kA

* For Econo Type Remove "B" From Code eg. NS16

Dimensions









Overall length	58.5mm	55.6mm	85.8mm	85.8mm	111mm	111mm
Hole fixing centres	CLIP-IN	44.5mm	73mm	73mm	93.7mm	93.7mm
Diameter	13.8mm	14.1mm	22.2mm	22.2mm	28mm	33.7mm
Tag type / holes	Offset / None	One side / 2	One side / 2	One side / 2	One side / 2	One side / 2

	NS Fuse Holders				NIT Fuse Holders - A1	
Volts	415V	415/660V	660V	550V	660V	415V
Mounting	Screw	Screw	Busbar	DIN	Screw	Screw
Neutral link for NS Fuse: NS-N						
Connection	Front	Rear	Rear/Front	Front	Front	Front
Black	NSH-B	NSP-B *	NSB-B	32NNSF-B	RS20H	CSM-20H
White	NSH-W	NSP-W *	-	32NNSF-W	-	-
	*Add 415V or 600V					











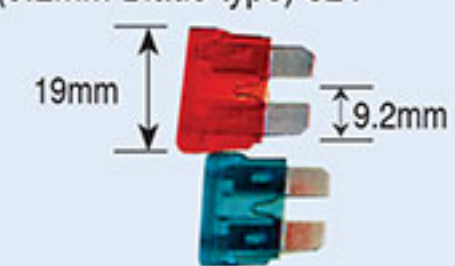



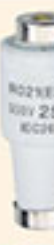



Dimensions						
Height	82.5mm	80mm	80mm	83mm	80mm	81mm
Width	44mm	25mm	25mm	25mm	27mm	25mm
Depth	67mm	81mm	44mm	49mm	54mm	46mm

	TIA Fuse Holders - A2			TIS Fuse Holders - A3				TCP Fuse Holders - A4	
Volts	660V	660V	415V	660V	660V	660V	415V	660V	415V
Mounting	Screw	Screw	Screw	Screw	Screw	Screw	Screw	Screw	Screw
Connection	Front	Rear/Front	Front	Front	Rear	Rear/Front	Front	Front	Front
Black	RS32HD	RS32PH	CSM-32H	RS63HD	RS63P	RS63-B	CSM-63H	RS100HD	CSM-100H
Dimensions									
Height	103mm	103mm	98mm	110mm	105mm	110mm	110mm	140mm	130mm
Width	32mm	32mm	32mm	35mm	36mm	35mm	35mm	51mm	47mm
Depth	70mm	70mm	65mm	76mm	65mm	76mm	76mm	100mm	91mm

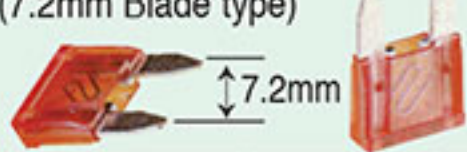
BS HRC LINKS & CARRIERS

BS 88 Size	B1	B2	B3	B4	C1/C2	C3	Fuse Holders Screw Mount Front Connection 
COOPER Bussmann Standard Protection IEC269 – BS88							
Code*	BTS*	BTF*	BTKF*	BTMF*	BTM*	BTTM*	BTLM*
Current (*Add Amp to code)	*100A	*125A *160A *200A	*250A *315A	*355A *400A	*400A	*500A *560A *630A	*800A
Voltage AC	660V	660V	660V	660V	660V	660V	660V
Fault capacity	80kA	80kA	80kA	80kA	80kA	80kA	80kA
* For Econo Type Remove "B" From Code eg. TS100							
Dimensions							
Overall length	136.5mm	136.5mm	136.5mm	136.5mm	211mm / 209.6mm	209.6mm	RS200HD 175 x 70 x 115
Hole fixing centres	111mm	111mm	111mm	111mm	133mm / 184mm	133mm / 184mm	TF 200A 415V 
Diameter	33.7mm	40 / 52.6mm	60mm	60mm	74.2mm	82.2mm	CSM-200H 176 x 70 x 125
Tag type / holes	Centre / 2	Centre / 2	Centre / 2	Centre / 2	Centre / 4	Centre / 4	

FUSES & HOLDERS

Bottle Fuses with blown indicator (diaized)						Automotive Fuses - 5 Pack (9.2mm Blade type) 32V		
Size	D01-E14	D02-E18	D1 – E16	D11 – E27	D111 – E33			
Standard Protection IEC269						Code/Amps	Colour	
Code	E14-*	E18-*	E16-*	E27-*	E33-*	AF-2A/5	● Dark Green	
Current	*2A		*2A	*2A		AF-3A/5	● Violet	
*Add Amp to code	*4A		*4A	*4A		AF-4A/5	● Pink	
	*6A		*6A	*6A		AF-5A/5	● Tan	
	*10A		*10A	*10A		AF-7.5A/5	● Brown	
	*16A		*16A	*16A		AF-10A/5	● Red	
50kA		*20A	*20A	*20A		AF-15A/5	● Blue	
		*25A	*25A	*25A		AF-20A/5	● Yellow	
		*35A			*35A	AF-25A/5	● Clear	
		*50A			*50A	AF-30A/5	● Green	
		*63A			*63A	AF-35A/5	● Purple	
Voltage AC	400V	400V	500V	500V	500V	Inline Fuse Holder 		
Dimensions Overall length	36mm	36mm	50mm	50mm	50mm	Code	V1161	
Diameter	11mm	14mm	13mm	22mm	26mm	(7.2mm Blade type)		
Fuse Holders Plastic, DIN Mount Base 400VAC IEC60269, VDE0636 Order Caps separately						Mini Automotive Fuses - 5 Pack (7.2mm Blade type) 		
Code 1P	PPD01-1	PPD02-1	PPE16-1	PPE27-1	PPE33-1	Code/Amps	Colour	
Code 3P	PPD01-3	PPD02-3	-	-	-	RL-3A/5	● Violet	
Cap Code	E14-CAP	E18-CAP	E16-CAP	E27-CAP	E33-CAP	RL-4A/5	● Pink	
Fuse Disconnectors – DIN Mount			Fuse Holders c/w Caps – DIN Mount			RL-5A/5		● Tan
						RL-7.5A/5	● Brown	
Code 1P	VLD01-1	STVD02-1	E16/1B	E27/1B	E33/1B	RL-10A/5	● Red	
Code 2P	VLD01-2	STVD02-2	-	-	-	RL-15A/5	● Blue	
Code 3P	VLD01-3	STVD02-3	E16/3B	E27/3B	E33/3B	RL-20A/5	● Yellow	
		Spare Caps	E16-CAP	E27-CAP	E33-CAP	RL-25A/5	● Clear	
						RL-30A/5	● Green	

ENCLOSED ONLOAD ISOLATORS

EXTENDED RANGE



25-40A

NEW

ABS Enclosed Isolators - c/w Padlockable Handle for up to 3 Padlocks, Indoor Use

3 Pole Code	4 Pole Code	Protection Rating	AC21@ 400/415V	AC22@ 400/415V	AC23@ 400/415V	AC23kW@ 400/415V	Dimensions HxWxD(mm)
KEM325UY/R-ABS	KEM425UY/R-ABS	IP65	40A	25A	25A	11kW	131 x 97 x 106
KEM340UY/R-ABS	KEM440UY/R-ABS	IP65	63A	40A	40A	22kW	131 x 97 x 106
KEM363UY/R-ABS	KEM463UY/R-ABS	IP65	80A	63A	63A	22kW	190 x 144 x 131
KEM380UY/R-ABS	KEM480UY/R-ABS	IP65	100A	80A	80A	30KW	190 x 144 x 131

Features

- Interlocked Handle
- Self-Extinguishing
- Good UV Resistance
- Good Chemical Resistance



63-125A



Polycarbonate Enclosed Isolators - c/w Padlockable Handle for up to 3 Padlocks, Outdoor Use, Good UV Resistance

3 Pole Code	4 Pole Code	Protection Rating	AC21@ 400/415V	AC22@ 400/415V	AC23@ 400/415V	AC23kW@ 400/415V	Dimensions HxWxD(mm)
KEM325UYR	KEM425UYR	IP66	40A	25A	25A	11KW	131 x 96 x 106
KEM340UYR	KEM440UYR	IP66	63A	40A	40A	22KW	131 x 96 x 106
KEM363UYR	KEM463UYR	IP66	80A	63A	63A	22KW	190 x 144 x 131
KEM380UYR	KEM480UYR	IP66	100A	80A	63A	30KW	190 x 144 x 131
KEM3100UYR	KEM4100UYR	IP66	125A	100A	80A	45KW	255 x 180 x 139
KEM3125UYR	KEM4125UYR	IP66	160A	125A	125A	55KW	255 x 180 x 139
KEM3160YR	KEM4160YR	IP65	160A	160A	160A	90KW	380 x 280 x 171
KEM3200YR	KEM4200YR	IP65	200A	200A	200A	110KW	560 x 380 x 240
KEM3250YR	KEM4250YR	IP65	250A	250A	250A	132KW	560 x 380 x 240
KEM3315YR	KEM4315YR	IP65	315A	315A	315A	160KW	560 x 380 x 240
KEM3400YR	KEM4400YR	IP65	400A	400A	400A	200KW	560 x 380 x 240
KEM3630YR	KEM4630YR	IP65	630A	630A	630A	355KW	760 x 560 x 310

160-630A



- Good UV Resistance
- IK08 - 25 - 160A
- IK10 - 200 - 250A

NEW

Aluminium Enclosed Isolators - c/w Padlockable Handle for up to 3 Padlocks

3 Pole Code	4 Pole Code	Protection Rating	AC21@ 400/415V	AC22@ 400/415V	AC23@ 400/415V	AC23kW@ 400/415V	Dimensions HxWxD(mm)
KEA325U	KEA425U	IP66	40A	25A	25A	11KW	159 x 104 x 116
KEA340U	KEA440U	IP66	63A	40A	40A	22KW	159 x 104 x 116
KEA363U	KEA463U	IP66	80A	63A	40A	22KW	262 x 162 x 143
KEA380U	KEA480U	IP66	100A	80A	63A	30KW	262 x 162 x 143
KEA3100U	KEA4100U	IP66	125A	100A	80A	45KW	262 x 162 x 143
KEA3125U	KEA4125U	IP66	160A	125A	125A	55KW	262 x 162 x 143
KEA3160U	KEA4160U	IP66	160A	160A	160A	90KW	262 x 162 x 143
KEA3200C	KEA4200C	IP65	200A	200A	200A	110KW	422 x 300 x 230
KEA3250C	KEA4250C	IP65	250A	250A	250A	132KW	422 x 300 x 230

Stainless Steel Enclosed Isolators - c/w Padlockable Handle, for up to 3 Padlocks

3 Pole Code	4 Pole Code	Protection Rating	AC21@ 400/415V	AC22@ 400/415V	AC23@ 400/415V	AC23kW@ 400/415V	Dimensions HxWxD(mm)
KER325Y/R	KER425Y/R	IP66	40A	25A	25A	11KW	180 x 120 x 115
KER340Y/R	KER440Y/R	IP66	63A	40A	40A	22KW	180 x 120 x 115
KER363Y/R	KER463Y/R	IP66	80A	63A	40A	22KW	280 x 160 x 128
KER380Y/R	KER480Y/R	IP66	100A	80A	63A	30KW	280 x 160 x 128
KER3100Y/R	KER4100Y/R	IP66	125A	100A	80A	45KW	280 x 160 x 128
KER3125Y/R	KER4125Y/R	IP66	160A	125A	125A	55KW	280 x 160 x 128
KER3160Y/R	KER4160Y/R	IP66	160A	160A	160A	90KW	420 x 300 x 161
KER3200Y/R	KER4200Y/R	IP65	200A	200A	200A	110KW	620 x 400 x 270
KER3250Y/R	KER4250Y/R	IP65	250A	250A	250A	132KW	620 x 400 x 270
KER3315Y/R	KER4315Y/R	IP65	315A	315A	315A	160KW	620 x 400 x 270
KER3400Y/R	KER4400Y/R	IP65	400A	400A	400A	200KW	620 x 400 x 270
KER3630Y/R	KER4630Y/R	IP65	630A	630A	630A	355KW	790 x 630 x 270

Full Stainless Steel Enclosed Isolators - c/w Padlockable Handle, Angled Top

3 Pole Code	4 Pole Code	Protection Rating	AC21@ 400/415V	AC22@ 400/415V	AC23@ 400/415V	AC23kW@ 400/415V	Dimensions HxWxD(mm)
KER325RS	KER425RS	IP66	40A	25A	25A	11KW	293 x 120 x 113
KER340RS	KER440RS	IP66	63A	40A	40A	22KW	293 x 120 x 113
KER363RS	KER463RS	IP66	80A	63A	40A	22KW	389 x 160 x 127
KER380RS	KER480RS	IP66	100A	80A	63A	30KW	389 x 160 x 127
KER3125RS	KER4125RS	IP66	160A	125A	100A	55KW	552 x 300 x 156
KER3160RS	KER4160RS	IP66	200A	160A	135A	75KW	552 x 300 x 156

25-160A IP66 AISI 316
200-630A IP65 AISI 304



- For Hygienic and Heavy Duty Applications
- Corrosion Resistant

ENCLOSED ISOLATORS IP66

NEW

6 Pole Polycarbonate Enclosed Isolators - for Motor Starter Isolation Applications
c/w Padlockable Handle for up to 3 padlocks



6 Pole Code	Protection Rating	AC21@ 400/415V	AC22@ 400/415V	AC23@ 400/415V	AC23kW@ 400/415V	Dimensions HxWxD(mm)
KEM625UY/R	IP66	40A	25A	25A	11kW	190 x 144 x 131
KEM640UY/R	IP66	63A	40A	40A	22kW	190 x 144 x 131
KEM663UY/R	IP66	80A	63A	40A	22kW	190 x 144 x 131
KEM680UY/R	IP66	100A	80A	63A	30kW	190 x 144 x 131
KEM6100UY/R	IP65	125A	100A	80A	45kW	380 x 280 x 171
KEM6125UY/R	IP65	160A	125A	125A	55kW	380 x 280 x 171
KEM6160UY/R	IP65	160A	160A	160A	90kW	380 x 280 x 171

6 Pole Aluminium Enclosed Isolators



6 Pole Code	Protection Rating	AC21@ 400/415V	AC22@ 400/415V	AC23@ 400/415V	AC23kW@ 400/415V	Dimensions HxWxD(mm)
KEA625U	IP66	40A	25A	25A	11KW	262 x 162 x 143
KEA640U	IP66	63A	40A	40A	22KW	262 x 162 x 143
KEA663U	IP66	80A	63A	40A	22KW	262 x 162 x 143
KEA680U	IP66	100A	80A	63A	30KW	263 x 162 x 143
KEA6100U	IP65	125A	100A	80A	45kW	422 x 300 x 230
KEA6125U	IP65	160A	125A	125A	55KW	422 x 300 x 230
KEA6160U	IP65	160A	160A	160A	90KW	422 x 300 x 230

EMC-Protected Polycarbonate Enclosed Isolators - for Variable speed drive applications, c/w Padlockable Handle for up to 3 Padlocks & Glands (EMC)



3 Pole Code	Protection Rating	AC21@ 400/415V	AC22@ 400/415V	AC23@ 400/415V	AC23kW@ 400/415V	Dimensions HxWxD(mm)
KEM325U/EMC-Y/R	IP66	40A	25A	25A	11KW	131 x 97 x 106
KEM340U/EMC-Y/R	IP66	63A	40A	40A	22KW	131 x 97 x 106
KEM363U/EMC-Y/R	IP66	80A	63A	40A	22KW	190 x 144 x 131
KEM380U/EMC-Y/R	IP66	100A	80A	63A	30KW	190 x 144 x 131
KEM3100U/EMC-Y/R	IP66	125A	100A	80A	45KW	225 x 180 x 139
KEM3125U/EMC-Y/R	IP66	160A	125A	125A	55KW	225 x 180 x 139

Fire Rated Aluminium Enclosed Isolators - Rated at 200°C for three hours, c/w Padlockable Handle for up to 3 Padlocks



3 Pole F200 Code	4 Pole F200 Code	Protection Rating	AC21@ 400/415V	AC22@ 400/415V	AC23@ 400/415V	AC23kW@ 400/415V	Dimensions HxWxD(mm)
KEA325UFR*	KEA425UFR*	IP66	40A	25A	25A	11KW	159 x 104 x 116
KEA340UFR*	KEA440UFR*	IP66	63A	40A	40A	22KW	159 x 104 x 116
KEA363UFR*	KEA463UFR*	IP66	80A	63A	40A	22KW	262 x 162 x 143
KEA380UFR*	KEA480UFR*	IP66	100A	80A	63A	30KW	262 x 162 x 143
KEA3125UFR*	KEA4125UFR*	IP65	160A	125A	100A	55KW	422 x 300 x 230
KEA3160UFR*	KEA4160UFR*	IP65	200A	160A	135A	75KW	422 x 300 x 230
KEA3200CFR*	KEA4200CFR*	IP65	200A	200A	200A	110KW	422 x 300 x 230

* Add 3 for F300 Rating 300°C for two hours

FIREMAN SWITCHES IP66

3 Pole Aluminium Side Operated Fire Switches



Code	Description	AC21@ 400/415/ 690V	AC22@ 400/415V 690V	AC23@ 400/415V	AC23kW@ 400/415V	AC23kW@ 690V	Dimensions HxWxD(mm)
KEF316A	16A 3P Side Operated	16A	16A	16A	7.5KW	11KW	157 x 103 x 80
KEF340A	63A 3P Side Operated	40A	40A	40A	22KW	22KW	157 x 103 x 80

- Fully Rated Load Break Switch, with Breaking Capacity of 8 x AC23 Rating
- Good UV Resistance
- High Impact Resistance
- Handle Padlockable in Off Position

ENCLOSED ISOLATORS



Surface Mounting **IP65** with padlockable red/yellow handle

Code	Pole	AC21 400V	AC23 400V	Terminal Capacity	Dimensions H x W x D	Qty/ Box
ESD2-3125ME	3	125A	45kW	35mm ²	185 x 142 x 104	1
ESD2-4125ME	4	125A	45kW	35mm ²	190 x 147 x 104	1



Aluminium Die-Cast Enclosed Isolators **IP65** (4 x M25 x 1.5mm Entries)

Code 3-Pole	Code 4-Pole	AC23	Dimensions L x W x D
ELCL-CSSD025D3	ELCL-CSSD025D4	25A	95 x 95 x 90
ELCL-CSSD040D3	ELCL-CSSD040D4	40A	95 x 95 x 90

FIRE RATED SWITCH DISCONNECTOR **IP65**



Designed to meet EN-12101-3 which specifies temperature/time requirements for Powered Smoke and Heat Exhaust fans in order to maintain safety under emergency conditions.

EN-12101-3/ F300:



The switch will be operational after 1 hour at 300°C.

EN-12101-3/ F400:



The switch will be operational after 2 hours at 400°C.



25A



40-63A



100 - 125A

* Four and Six Pole Only Available Ex - Indent

NEW 3 Pole Code	AB55225F3	AB55221F4	AB55241F4	AB55261F4	AB55271F4	AB55291F4
3 Pole + 1 Aux (1NO + 1NC) Code	AB55225F3-A	AB55221F4-A	AB55241F4-A	AB55261F4-A	AB55271F4-A	AB55291F4-A
NEW 4 Pole Code	AB55325F3	AB55321F4	AB55341F4	AB55361F4	AB55371F4	AB55391F4
NEW 6 Pole Code	AB55625F3	AB55621F4	AB55641F4	AB55661F4	AB55671F4	AB55691F4
Temperature Rating to EN12101-3	F300	F400	F400	F400	F400	F400
Rated Current In	25A	25A	40A	63A	100A	125A
Thermal Rating Ith	30A	30A	50A	70A	120A	125A
Rated Operating Voltage	690VAC	690VAC	690VAC	690VAC	690VAC	690VAC
AC23kW @ 400 VAC	7.5kW	7.5kW	18.5kW	22kW	30kW	37kW
Size L x W x H (mm)	100 x 100 x 106	130 x 130 x 124	160 x 160 x 124	160 x 160 x 124	250 x 250 x 145	250 x 250 x 145

FIREMANS EMERGENCY SWITCHES



For Illuminated Signs – Weatherproof – **IP65**



38042



38052

Code	Description	Size
38042	Double pole 16A 250V (ACI) Red	Size: 143 x 100 x 65(D) mm
38052	Four Pole 16A 250V (ACI) Grey	Size: 172 x 101 x 73(D)mm

Safety Features

- Circuit breaking possible using fireman's baton, or similar object.
- Box impossible to open when power is on
- Automatic locking device in "off" position to prevent accidental switching on
- Plastic enclosure, glow wire tested in accordance with IEC 60 695-2-1.1

COMPACT ISOLATORS



Fused Isolator



Isolator

Amps AC22		16A	32A	50A	63A	80A	100A
Fused Isolator	3P	VQ413800	VQ422900	-	-	-	-
	4P	VQ416100	VQ425200	-	-	-	-
Isolator only	3P	VQ362700	VQ380900	VQ355100	VQ356900	VQ357700	VQ358500
	4P	VQ365000	VQ383300	-	-	-	-

16A Fused isolators use 10x38 fuses, 32A Fused isolators use 14x51. For fuses see page 210

Accessories for XNF Type Fused Isolator

Code	Description	
VC301000	1 NO aux contact block 16A	VC301000
VC300200	1 NC aux contact block 16A	VC300200
VC303600	1 NO aux contact block 32A	VC303600
VC302800	1 NC aux contact block 32A	VC302800



Fused Isolator & Isolator supplied with **IP65** ON/OFF Handle & Shaft

EXTENDED RANGE

COMPACT ISOLATORS

DC Ratings Available on Request

DIN Rail Mount Isolators - Order operating handle & shaft separately (Padlockable for 3 Padlocks)



KU 25-80A

KU 100-160A

Code 3 Pole	Code 4 Pole ^{NEW}	AC22 @ 400/415/690V	AC23 @ 400/415V	AC23 kW @ 400/415V	AC23 kW @ 690V	3 Pole Size H x W x D	4 Pole Size H x W x D
KU325N	KU425N	25A	25A	11kW	22kW	74 x 50 x 73	74 x 65 x 73
KU340N	KU440N	40A	32A	15kW	30kW	74 x 50 x 73	74 x 65 x 73
KU363N	KU463N	63A	40A	22kW	37kW	74 x 50 x 73	74 x 65 x 73
KU380N	KU480N	80A	63A	30kW	37kW	74 x 50 x 73	74 x 65 x 73
^{NEW} KU3100	^{NEW} KU4100	100A	100A	55kW	55kW	100 x 70 x 87	100 x 94 x 87
^{NEW} KU3125	^{NEW} KU4125	125A	125A	55kW	75kW	100 x 70 x 87	100 x 94 x 87
^{NEW} KU3160	^{NEW} KU4160	160A	160A	90kW	90kW	100 x 70 x 87	100 x 94 x 87
VKA3125N	VKA4125N	125A	100A	55kW	55kW	82 x 79.0 x 82	82 x 99 x 82
VKA3160N	VKA4160N	160A	135A	75kW	90kW	82 x 79.0 x 82	82 x 99 x 82

Accessories

Code	Description
------	-------------

Aux Contact Arrangements

KU1V	Aux Contact 1NO/1NC for KU 25-80A
KU2V	Aux Contact 2NO/2NC for KU 25-80A
1.V160KU	Aux Contact 1NO/1NC for KU 100-160A
2.V160KU	Aux Contact 2NO/2NC for KU 100-160A
VKA1V	Aux Contact 1NO/1NC for VKA 25-125A
VKA2V	Aux Contact 2NO/2NC for VKA 25-125A

Shafts

L100AD11	100mm Alu Shaft for KU/VKA
L200AD11	200mm Alu Shaft for KU/VKA
L300AD11	300mm Steel Shaft for KU/VKA

Handles On/Off IP66 - Padlockable, accepts up to 3 padlocks

LK10	Black Handle for KU 25 - 80A
LK10YR	Yellow & Red Handle for KU 25-80A
LK11	Black Handle for KU/VKA 125-160A
LK11YR	Yellow & Red Handle for KU/VKA 125-160A
LK2/OK2	Economy Yellow & Red Handle for KU 25-80A

Spreader Connection Bars

ALK3160	Spreader Bars for VKA 125-160A for 3 Pole
ALK4160	Spreader Bars for VKA 125-160A for 4 Pole

Parallel Kit (Handle and Shaft to be ordered separately)

RV52S	Offset Parallel kit for 2 x KU 25-80A 3P Switches
PK160KU	Parallel kit for KU 100-160A 3P Switches
RV80S	Offset Parallel kit for 2 x VKA 3P Switches
RV104S	Offset Parallel kit for 2 x VKA 3P Switches + 2 x Spreader Kit (ALK3160)

Change-Over Kits

LK12 1-0-2	Black Handle for changeover kits
L300AD12/VT	300mm Steel Shaft for changeover kits
KU3/4P VV	Changeover Kit for KU 25-80A
CO160KU	Changeover Kit for KU 100-160A
VV1.V	Auxiliary contact for changeover kits (Max 2 Installed per kit)

• Compact design for 2 KU-switches • Fast and easy to install • Supplied with black direct handle

Door Mounting Kits

OKA/KU/LK10	Black, for KU 25-80A 3P switch, with LK10 handle
OKA/KU/LK10Y/R	Yellow/red, for KU 25-80A 3P switch, with LK10 handle
OKA/KU4P/LK10	Black, for KU 25-80A 4P switch, with LK10 handle
OKA/KU4P/LK10Y/R	Yellow/Red, for KU 25-80A 4P switch, with LK10 handle
OKA/VKA	Black, for VKA 125-160A 3P switch, with LK11 handle
OKA/VKAY/R	Yellow/Red, for VKA 125-160A 3P switch, with LK11 handle
OKA/VKA4P	Black, for VKA 125-160A 4P switch, with LK11 handle
OKA/VKA4PY/R	Yellow/Red, for VKA 125-160A 4p switch, with LK11 handle

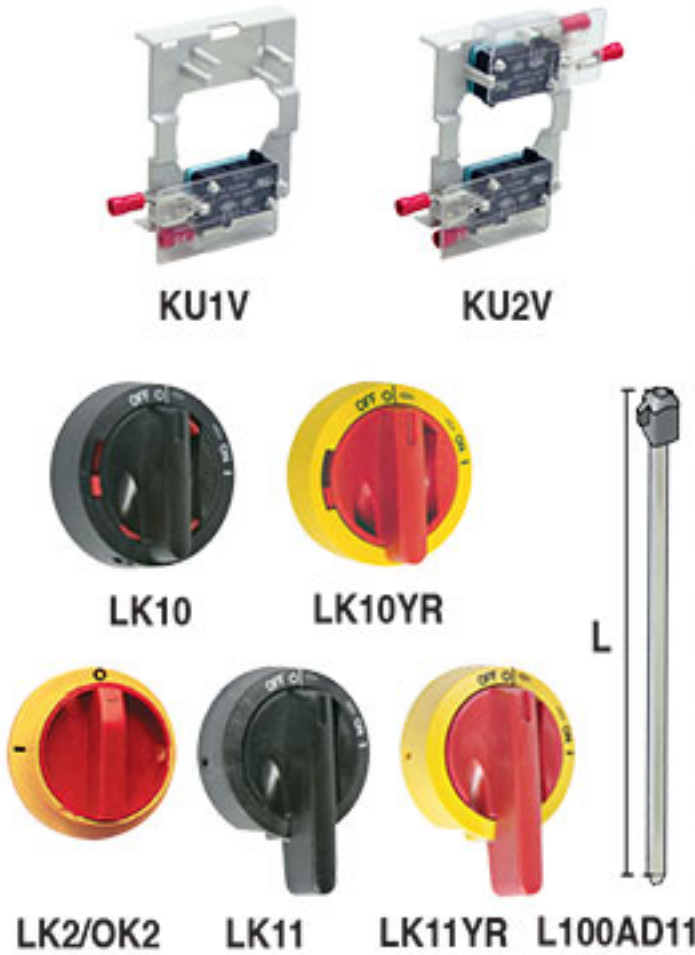

L



VKA with ALK3160 Fitted

RV52S



KU3/4P VV



OKA/KU
OKA/VKA

LARGE FRAME ISOLATORS

- Includes Fuse Covers, Excludes Terminal Covers
- Dimensions Exclude Terminal Covers
- 63-160A Includes Handle LK12 and Shaft L=220mm
- 200-630A Includes Handle LK14 and Shaft L=228mm

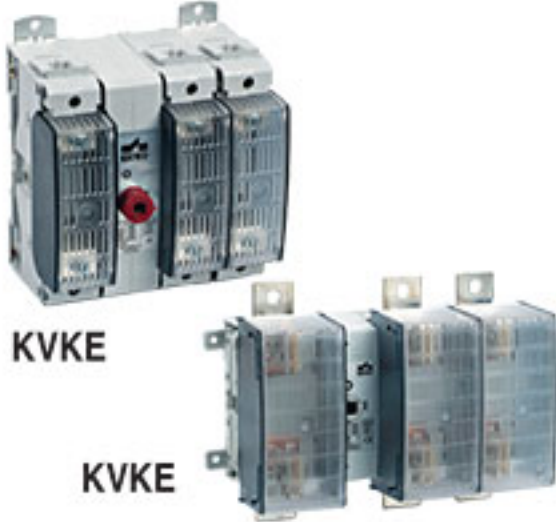

Din Fused Isolators - Switch is supplied c/w operating handle and shaft (Padlockable for 3 padlocks)

Code DIN	Fuse Size	Code BS	Fuse Size	AC22 @ 400/415/690V	AC23 @ 400/415V	AC23 KW @ 400/415V	AC23 KW @ 690V	Size H x W x D
KVKE332AD	10 x 38	KVKE332ABS	A1	32A	32A	15KW	-	102 x 108 x 92
KVKE363AD	00	KVKE363ABS	A2-A3	63A	63A	30KW	55KW	163 x 146 x 118
KVKE380AD	00	KVKE380ABS	A2-A3	80A	80A	40KW	75KW	163 x 146 x 118
KVKE3100AD	00	KVKE3100ABS	A2-A3	100A	100A	55KW	90KW	163 x 146 x 118
KVKE3125AD	00	KVKE3125ABS	A2-A3	125A	125A	55KW	110KW	163 x 146 x 118
KVKE3160AD	00	KVKE3160ABS	B1-B2	160A	160A	55KW	110KW	163 x 146 x 118
KVKE3200AD	1	KVKE3200ABS	B1-B3	200A	200A	110KW	160KW	217 x 234 x 128
KVKE3250AD	1	KVKE3250ABS	B1-B4	250A	250A	132KW	250KW	217 x 234 x 128
KVKE3315AD	2	KVKE3315ABS	B1-B4	315A	315A	160KW	315KW	224 x 271 x 140
KVKE3400AD	2	KVKE3400ABS	B1-B4	400A	400A	200KW	355KW	224 x 271 x 140
KVKE3630AD	3	KVKE3630ABS	B1-B4	630A	630A	355KW	500KW	236 x 293 x 151

On Load Isolators

Switch is supplied, c/w operating handle and shaft (Padlockable for 3 Padlocks)



Code 3 Pole	Code 4 Pole NEW	AC22 @ 400/415/690V	AC23 @ 400/415V	AC23 kW @ 400/415V	AC23 kW @ 690V	Size H x W x D
VKE3125	VKE4125	125A	125A	55kW	90kW	163 x 146 x 94
VKE3160	VKE4160	160A	125A	55kW	90kW	163 x 146 x 94
VKE3200	VKE4200	200A	200A	110kW	160kW	217 x 234 x 101
VKE3250	VKE4250	250A	250A	132kW	250kW	217 x 234 x 101
VKE3315	VKE4315	315A	315A	160kW	315kW	224 x 271 x 101
VKE3400	VKE4400	400A	400A	200kW	355kW	224 x 271 x 101
VKE3630	VKE4630	630A	630A	355kW	500kW	238 x 307 x 101

Accessories for VKE and KVKE

Code	Description
Aux Contact Arrangements	
KVKEC1V	Aux Contact 1N0/1NC for KVKE 32A
KVKEC2V	Aux Contact 2N0/2NC for KVKE 32A
KVKE1V	Aux Contact 1N0/1NC for KVKE/VKE 63-630A
KVKE2V	Aux Contact 2N0/2NC for KVKE/VKE 63-630A
Shafts	
L100AD12T	100mm Steel Shaft for KVKE/VKE 63-160A & LK12
L200AD12T	200mm Steel Shaft for KVKE/VKE 63-160A & LK12
L300AD12T	300mm Steel Shaft for KVKE/VKE 63-160A & LK12
LVK228	228mm Steel Shaft for KVKE/VKE 200-630A & LK13 & LK14
LVK320	300mm Steel Shaft for KVKE/VKE 200-630A & LK13 & LK14
Handles On/Off IP65 - Padlockable	
LK12	Black Handle for KVKE/VKE 125-160A
LK12YR	Yellow & Red Handle for KVKE/VKE 125-160A
LK13	Black Handle for KVKE/VKE 200-400A
LK13YR	Yellow & Red Handle for KVKE/VKE 200-400A
LK14	Black Handle for KVKE/VKE 200-630A
LK14YR	Yellow & Red Handle for KVKE/VKE 200-630A
Terminal Covers	
LS125	VKE 125-160A & KVKE 63-160A
LS250	VKE 200-250A & KVKE 200-250A
LS400	VKE 315-400A & KVKE 315-400A
LS630	VKE 630A & KVKE 630A
Spreader Connection Bars	
KVKEALK1603P	Spreader bars for KVKE/VKE 125-160A 3 Pole Switches
KVKEALK1604P	Spreader bars for KVKE/VKE 125-160A 4 Pole Switches

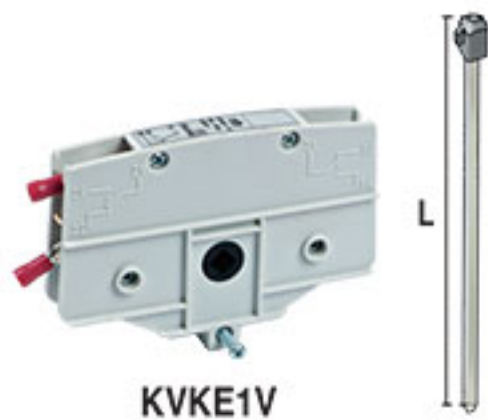

KVKE1V



LK12

LK12YR



LK13

LK13YR



LK14

LK14YR

ONLOAD ISOLATORS

Open Isolators 25...3150A Ue 690V

25-63A supplied with red/yellow padlockable handle and 70mm shaft. For longer shaft order separately.
125-3150A supplied with padlockable pistol-grip handle and shaft.

DIN Rail mounting: 25 & 40A (3 & 4 pole) plus 63A 3 pole. All others are screw mounting.



25-63A D Type



125A D Type



125-160A DM Type



200-800A



1000-1250A

3-Pole Code	4-Pole Code	Ie 690V	AC23A 415V	kVAr 415V	Dimensions 3/4 Pole (mm)	
					W/W x H x D	Panel Depth
CSSD0025D3	CSSD0025D4	25A	25A	10	51/62 x 60 x 68	85-110
CSSD0040D3	CSSD0040D4	40A	40A	12.5	51/62 x 60 x 68	85-110
CSSD0063D3	-	63A	63A	30	53 x 84 x 68	85-110
-	CSSD0063D4	63A	63A	30	110 x 97 x 75	85-110
CSSD0125D3	CSSD0125D4	125A	125A	35	110 x 97 x 75	85-110
CSSD0125DM3	CSSD0125DM4	125A	125A	50	190/230 x 142 x 90	135-235
CSSD0160DM3	CSSD0160DM4	160A	160A	60	190/230 x 142 x 90	135-235
CSSD0200DM3	CSSD0200DM4	200A	200A	90	193/292 x 175 x 105	190-300
CSSD0250DM3	CSSD0250DM4	250A	250A	115	193/292 x 175 x 105	190-300
CSSD0315DM3	CSSD0315DM4	315A	315A	145	193/292 x 175 x 105	190-300
CSSD0400DM3	CSSD0400DM4	400A	400A	250	230/292 x 175 x 105	190-300
CSSD0630K3	CSSD0630K4	630A	630A	300	244/306 x 223 x 130	220-325
CSSD0800K3	CSSD0800K4	800A	720A	330	260/330 x 223 x 130	220-325
CSSD1000K3	CSSD1000K4	1000A	1000A	-	343/423 x 372 x 125	240-310
CSSD1250K3	CSSD1250K4	1250A	1000A	-	343/423 x 372 x 125	240-310
CSSD1600K3	CSSD1600K4	1600A	1000A	-	461/600 x 372 x 125	240-310
CSSD1800K3	CSSD1800K4	1800A	1000A	-	461/600 x 372 x 125	240-310
CSSD2000K3	CSSD2000K4	2000A	1000A	-	468/607 x 352 x 271	340-450
CSSD2500K3	CSSD2500K4	2500A	1000A	-	468/607 x 352 x 271	340-450
CSSD3200K3	CSSD3200K4	3150A	1000A	-	468/607 x 352 x 271	340-450

Order shaft separately

Complete with Shaft and Handle

Values not specified are available on application

Enclosed Isolators IP54

For any of the above to be supplied in a steel enclosure, add the prefix "E-". and -G (Grey) or -O (Orange) e.g. **E-CSSD0160DM3-G**



Accessories



CSSDZX49



CSSDZX108



CSSDZX111BL



CSWH80S6



CSWH145S12



CSP6X165



CSSDB1/2/3/4



CSSDZW6/1

Switch size	25-40D	63D	125D*	125-160DM	200-315DM	400-800D/K	1000-1800K
Spare Handle – Black padlockable (IP54) Red/Yellow	CSSDZX111BL CSSDZX108	CSSDZX111BL CSSDZX108	CSSDZX111BL CSSDZX108	CSWH80S6* -	CSWH80S8* -	CSWH145S12* -	CSWH220S12* -
Shaft – Size (mm)	5 ² x 150	5 ² x 150	5 ² x 150	6 ² x 165	8 ² x 240	12 ² x 255	12 ² x 255
Code	CSP5X150	CSP5X150	CSP5X150	CSP6X165	CSP8X240	CSP12X255	CSP12X255
Support bracket	CSSDB1 (70mm)	CSSDB1 (70mm)	CSSDB2 (70mm)	CSSDB4 (70mm) CSSDB3 (150mm)	-	-	-
Changeover mechanism	CSSDZW6/1†	CSSDZW6/1†	CSSDZW6/1†	-	-	CSSFZW11	-
Aux. Contact – 1NO + 1NC	CSSDZX49	CSSDZX79	CSSDZX52	CSSDZX1	CSSDZX37	CSSDZX33	CSSDZX35
3P 2NO + 2NC	CSSDZX50	CSSDZX80	CSSDZX53	CSSDZX16	CSSDZX38	CSSDZX34	CSSDZX36
Aux. Contact – 1NO + 1NC	CSSDZX87	CSSDZX55	CSSDZX55	CSSDFZX 1	CSSDZX37	CSSDZX33	CSSDZX35
4P 2NO + 2NC	CSSDZX88	CSSDZX56	CSSDZX56	CSSDFZX 16	CSSDZX38	CSSDZX34	CSSDZX36
Terminal shrouds	-	-	SF701	SF702	SF703	-	-

*These are supplied with the isolator and are offered for spares purposes only.

*For pistol Grip Handle use CSP5/6X160 Shaft + CSWH80S6 Handle

†Order CSP6X165 Shaft. CSWH80S6 Pistol Grip Handle supplied

FUSED ISOLATORS

Enclosed Version
Electric Orange

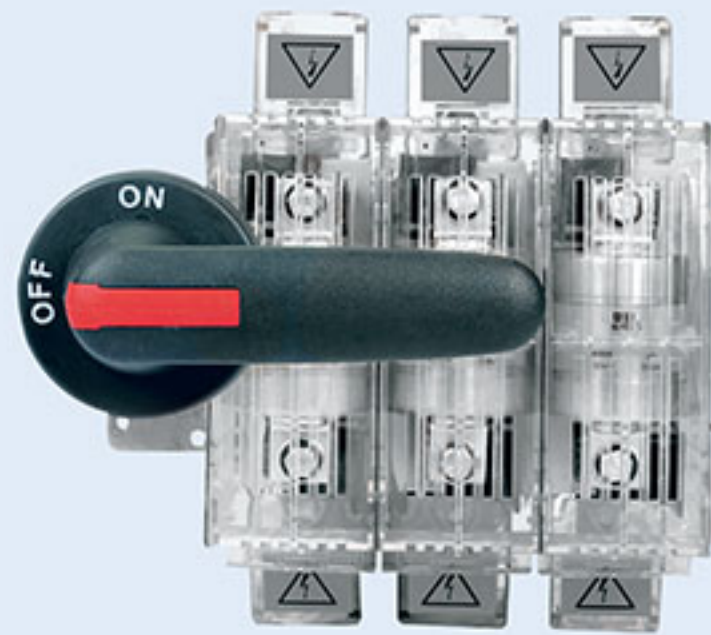

BS Type Fuse



DIN Type Fuse

All open fused isolators supplied complete with IP54 black handle and shaft.

3 Pole DIN Code	DIN Fuse Size	3 Pole BS Code	BS Fuse Size	AC23A 415V	kVAR Switching Capacity	DIN Dimensions H x W x D	BS Dimensions H x W x D	Enclosure Size H x W x D
CSSDF032D3	00	CSSDF032B3	A2	32A	15	107 x 168 x 126	107 x 168 x 126	300 x 250 x 200
CSSDF063D3	00	CSSDF063B3	A3	63A	30	107 x 168 x 126	107 x 168 x 126	300 x 250 x 200
CSSDF100D3	00	CSSDF100B3	A4	100A	45	142 x 190 x 134	142 x 190 x 134	300 x 250 x 200
CSSDF125D3	00	CSSDF125B3	A4	125A	50	142 x 190 x 134	142 x 190 x 134	300 x 250 x 200
CSSDF160D3	00	CSSDF160B3	B2	160A	60	142 x 212 x 135	142 x 212 x 134	300 x 250 x 200
CSSDF200D3	1	CSSDF200B3	B2	200A	90	200 x 261 x 184	200 x 261 x 184	500 x 400 x 200
CSSDF250D3	1	CSSDF250B3	B3	250A	115	200 x 261 x 184	200 x 261 x 184	500 x 400 x 200
CSSDF315D3	2	CSSDF315B3	B3	315A	145	200 x 285 x 184	200 x 285 x 184	500 x 400 x 200
CSSDF400D3	2	CSSDF400B3	B4	400A	180	200 x 285 x 184	200 x 285 x 184	500 x 400 x 200
CSSDF630D3	3	CSSDF630B3	C2	630A	250	320 x 343 x 223	320 x 403 x 223	800 x 600 x 320
CSSDF800D3	3	CSSDF800B3	C3	800A	310	320 x 373 x 223	320 x 403 x 223	800 x 600 x 320

For enclosed fused isolators IP55 add prefix "E-" to the above codes, eg. E-CSSDF200D

- The fused isolators conform to IEC 60947 part 3.
- Max operational voltage without derating 690V.
- Utilisation category AC23A@415V.
- Rated insulation voltage U_i 750V. Impulse withstand voltage U_{imp} 12kV.
- Conventional enclosed thermal rating 45°C

Accessories



CSSDFZX 33/36



CSSDFZX 1/16



CSSFZW



CSWH8056



CSWH145512



CSP

Isolator Size	Auxiliary Contact 1NO+1NC	Auxiliary Contact 2NO+2NC	Change Over Mechanism	Spare Handle Code IP54	Spare Shaft Code
32-63A	CSSDFZX 46	CSSDFZX 32	CSSFZW1	CSWH80S6	CSP6X165
100-160A	CSSDFZX 1	CSSDFZX 16	CSSFZW1	CSWH80S6	CSP6X165
200-400A	CSSDFZX 33	CSSDFZX 34	CSSFZW12/1	CSWH145S12	CSP12X255
630-800A	CSSDFZX 35	CSSDFZX 36	CSSFZW12/1	CSWH220S12	CSP12X255

ISOLATORS



Isolators - c/w Handle and 360mm Shaft

NOTE: Accessories supplied with switch
 YGL 125A-630A - YU-3, YU-8
 YGL 800A-3150A - YU-4, YU-5, YU-10, YU-12,
 YU-13, YU-14
 See accessories for additional spare parts
 on page 224



Enclosed Version

Open Code 3 Pole	Open Code 4 Pole	KA RMS For 1 Sec	AMPS AC21 @ 400V	AMPS AC23 @ 400V	Dimensions 3 Pole (H x W x D)	Dimensions 4 Pole (H x W x D)
YGL-0125/3P	YGL-0125/4P	10	125	125	135 x 140 x 120	135 x 170 x 120
YGL-0160/3P	YGL-0160/4P	10	160	160	135 x 140 x 120	135 x 170 x 120
YGL-0200/3P	YGL-0200/4P	12	200	200	165 x 180 x 140	165 x 230 x 140
YGL-0250/3P	YGL-0250/4P	12	250	250	165 x 180 x 140	165 x 230 x 140
YGL-0315/3P	YGL-0315/4P	20	315	315	234 x 230 x 140	234 x 290 x 140
YGL-0400/3P	YGL-0400/4P	20	400	340	234 x 230 x 185	234 x 290 x 185
YGL-0500/3P	YGL-0500/4P	25	500	425	250 x 230 x 185	250 x 290 x 185
YGL-0630/3P	YGL-0630/4P	25	630	500	250 x 230 x 185	250 x 290 x 185
YGL-0800/3P	YGL-0800/4P	50	800	630	328 x 378 x 354	328 x 492 x 440
YGL-1000/3P	YGL-1000/4P	50	1000	800	328 x 378 x 354	328 x 492 x 440
YGL-1250/3P	YGL-1250/4P	50	1250	1000	336 x 378 x 354	336 x 492 x 440
YGL-1600/3P	YGL-1600/4P	50	1600	1250	336 x 378 x 354	336 x 492 x 440
YGL-2000/3P	YGL-2000/4P	50	2000	1250	422 x 378 x 354	422 x 492 x 440
YGL-2500/3P	YGL-2500/4P	50	2500	1250	432 x 378 x 354	432 x 492 x 440
YGL-3150/3P	YGL-3150/4P	50	3150	1250	442 x 378 x 354	442 x 492 x 440

NOTE: For enclosed models add: EO- (Orange) or EG- (Grey) to beginning of code eg.: EO-YGL-0160/3P

ONLOAD ISOLATOR, CHANGEOVER & BYPASS SWITCHES

Gawe

Supplied c/w black
operating handle.
Door mount kits
to be ordered
separately.



63-80A



100-125A



160-250A



Integrated Link

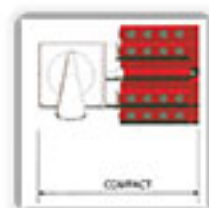

Compact Size
Integrating two circuits on
each cell permits an extra
compact size. Up to 40%
space saving to conventional
switches.



Installation
Designed to mount
directly on DIN Rail.

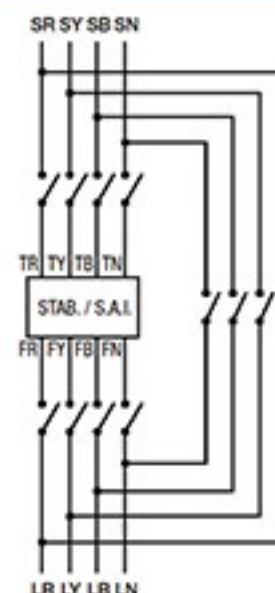

Bypass Switch
Switching Scheme for use
with Voltage Stabilisers.

Rated Operational Current	63A	80A	100A	125A	160A	200A	250A
Code 3 pole isolator switch	LQ5526100	LQ5528100	LQ5527100	LQ5529100	LQ552A100	LQ552B100	LQ552C100
Code 4 pole isolator switch	LQ5536100	LQ5538100	LQ5537100	LQ5539100	LQ553A100	LQ553B100	LQ553C100
Code 3 pole changeover switch	LQ5626100	LQ5628100	LQ5627100	LQ5629100	LQ562A100	LQ562B100	LQ562C100
Code 4 pole changeover switch	LQ5636100	LQ5638100	LQ5637100	LQ5639100	LQ563A100	LQ563B100	LQ563C100
Code 4 Pole Bypass Switch	L271F6100	-	L271F7100	L271F9100	L271FA100	L271FB100	L271FC100
Rated operating voltage	690VAC	690VAC	690VAC	690VAC	690VAC	690VAC	690VAC
AC21 Kw @ 400V	37	45	55	75	90	110	132
AC23 Kw @ 400V	22	30	30	37	52	65	-
Maximum cable size (mm ²)	16 - 50	16-50	16-50	16-50	70	95	120
Terminal type	Screw	Screw	Screw	Screw	Bolt	Bolt	Bolt



LK1720006



AK2240006



AK1200146



AK1200526



AK1200148



AK1200528

Accessories

Code	Description
LK1720006	Door Mounting Kit with 200mm shaft & door interlock
LK0800006	Door Mounting Kit 200mm shaft extension
AK1200146	Black/Grey Padlockable Handle for 63-80A
AK1200148	Black/Grey Padlockable Handle for 100-250A
AK1200526	Red/Yellow Padlockable Handle for 63-80A
AK1200528	Red/Yellow Padlockable Handle for 100-250A
AK2240006	IP65 Gasket for Door Mounted Handles

CHANGEOVER SWITCHES - CS SERIES



Enclosed Version



CO1

Change Over Switches

Supplied with shaft and Padlockable "pistol grip" handle. Ue = 690V

Code 3 Pole	Code 4 Pole	Ith	AC22 @415V	AC23 @415V	Dimensions 3/4 Pole (mm)	
					W/W x H x D	Panel Depth
CSCS0160DM3CO	CSCS0160DM4CO	160A	160A	160A	215/255 x 142 x 182	195-295
CSCS0200DM3CO	CSCS0200DM4CO	200A	200A	200A	248/309 x 163 x 242	255-355
CSCS0250DM3CO	CSCS0250DM4CO	250A	250A	250A	248/309 x 163 x 242	255-355
CSCS0315DM3CO	CSCS0315DM4CO	315A	315A	315A	248/309 x 163 x 242	255-355
CSCS0400K3CO	CSCS0400K4CO	400A	400A	400A	282/352 x 205 x 262	300-400
CSCS0630K3CO	CSCS0630K4CO	630A	630A	630A	282/352 x 223 x 262	300-400
CSCS0800K3CO	CSCS0800K4CO	800A	800A	720A	282/352 x 223 x 262	300-400
CSCS1000K3CO	CSCS1000K4CO	1000A	1000A	800A	396/496 x 352 x 260	330-450
CSCS1250K3CO	CSCS1250K4CO	1250A	1250A	800A	396/496 x 352 x 260	330-450
CSCS1600K3CO	CSCS1600K4CO	1600A	1600A	800A	396/496 x 352 x 260	330-450
CSCS2500K3CO	CSCS2500K4CO	2500A	1800A	-	436/556 x 352 x 552	590-690
CSCS3150K3CO	CSCS3150K4CO	3150A	1800A	-	436/556 x 352 x 552	590-690

IP54 Steel enclosed changeover switches. Prefix the above codes with "E-". e.g. **E-CSCS0630K4CO**

For rating below 160A/64kVA, use 2 isolators plus changeover mechanism. See page 220

Auxiliary Contacts

Code	Contact Config	For Switch Type	Qty/ Switch
CSCSZX1-U	1NO + 1NC	160A	1
CSCSZX1-L	1NO + 1NC	160A	1
CSCSZX3-U	2NO + 2NC	160A	1
CSCSZX3-L	2NO + 2NC	160A	1
CSCSZX2	1NO + 1NC	200 - 3150A	2
CSCSZX4	1NO + 2NC	200 - 3150A	2

Spare Handle & Handle Shafts

Code	Description
CCOH145S8	Spare Handle for 63 - 315A
CCOH220S12	Spare Handle for 400 - 1800A
CSDA6	Spare Handle for 2000 - 3150A
CSP8X200	Handle Shaft for 63 - 315A
CSP12X205	Handle Shaft for 400 - 1800A
CSP12X305	Handle Shaft for 2000 - 3150A

CHANGE OVER SWITCHES

Each switch is supplied c/w:
Padlockable Handle, Extension shaft, Joint sleeve, Face plate, Door plate, Ext shaft joint and Copper Bridge Pieces.
Switch includes auxiliary contacts: 2NO & 2NC.
See accessories for additional spare parts on page 224



Enclosed Version

Open Code 3 Pole	Open Code 4 Pole	KA RMS For 1 Sec	AMPS AC21 @ 400V	AMPS AC23 @ 400V	Open Dimensions		Closed Dimensions	
					3 Pole	4 Pole	3 Pole	4 Pole
YGLZ1-0125/3P	YGLZ1-0125/4P	10	125	125	135 x 274 x 166	135 x 304 x 215	400 x 350 x 380	450 x 350 x 380
YGLZ1-0160/3P	YGLZ1-0160/4P	10	160	160	135 x 274 x 166	135 x 304 x 215	400 x 350 x 380	450 x 350 x 380
YGLZ1-0200/3P	YGLZ1-0200/4P	12	200	200	165 x 347 x 250	165 x 396 x 250	470 x 420 x 400	570 x 420 x 400
YGLZ1-0250/3P	YGLZ1-0250/4P	12	250	250	165 x 347 x 250	165 x 396 x 250	470 x 420 x 400	570 x 420 x 400
YGLZ1-0315/3P	YGLZ1-0315/4P	20	315	315	234 x 432 x 325	234 x 492 x 325	600 x 580 x 500	720 x 580 x 500
YGLZ1-0400/3P	YGLZ1-0400/4P	20	400	340	234 x 432 x 325	234 x 492 x 325	600 x 580 x 500	720 x 580 x 500
YGLZ1-0500/3P	YGLZ1-0500/4P	25	500	425	250 x 432 x 325	250 x 492 x 325	600 x 580 x 500	720 x 580 x 500
YGLZ1-0630/3P	YGLZ1-0630/4P	25	630	500	250 x 432 x 325	250 x 492 x 325	600 x 580 x 500	720 x 580 x 500
YGLZ1-0800/3P	YGLZ1-0800/4P	50	800	630	328 x 583 x 390	328 x 698 x 390	950 x 820 x 550	950 x 820 x 550
YGLZ1-1000/3P	YGLZ1-1000/4P	50	1000	800	328 x 583 x 390	328 x 698 x 390	950 x 820 x 550	950 x 820 x 550
YGLZ1-1250/3P	YGLZ1-1250/4P	50	1250	1000	336 x 583 x 390	336 x 698 x 390	950 x 820 x 550	950 x 820 x 550
YGLZ1-1600/3P	YGLZ1-1600/4P	50	1600	1250	336 x 583 x 390	336 x 698 x 390	1340 x 820 x 600	1540 x 820 x 600
YGLZ1-2000/3P	YGLZ1-2000/4P	50	2000	1250	422 x 583 x 568	422 x 698 x 568	1440 x 820 x 770	1540 x 820 x 770
YGLZ1-2500/3P	YGLZ1-2500/4P	50	2500	1250	432 x 583 x 568	422 x 698 x 568	1440 x 820 x 770	1540 x 820 x 770

NOTE: For enclosed models add: **EO-** (Orange) or **EG-** (Grey) to beginning of code eg.: **EG-YGLZ1-0160/3P**

MOTORISED CHANGE OVER SWITCHES

Supplied with manual operating handle.

Copper Bridge Pieces included



YES1 type Automatic Transfer Switch (ATS) Integrates control logic an electromechanical switch into a single housing without the requirements of additional controllers. Internally fitted with Aux contact 1 NO + 1 NC.



Open Type Code - 3 Pole	Open Type Code - 4 Pole	KA RMS for 1 Second	Internal Motor Watts	Switch Over Time in Secs	Amps @ AC21 400V	Amps @ AC23 400V	Open 4 Pole Size H x W x D (mm)
-	YES1-0040GA4P	7	300	0.45	40	40	106 x 279 x 169
-	YES1-0063GA4P	7	300	0.45	63	63	106 x 279 x 169
-	YES1-0080GA4P	7	300	0.45	80	80	106 x 279 x 169
YES1-0100GA3P	YES1-0100GA4P	7	300	0.45	100	100	106 x 279 x 169
-	YES1-0125GA4P	7	300	0.45	125	125	135 x 322 x 230
YES1-0160GA3P	YES1-0160GA4P	9	325	0.45	160	160	135 x 322 x 230
YES1-0250GA3P	YES1-0250GA4P	9	325	0.45	250	250	163 x 406 x 230
YES1-0400GA3P	YES1-0400GA4P	13	355	0.6	400	400	234 x 552 x 230
YES1-0630GA3P	YES1-0630GA4P	13	355	0.6	630	400	328 x 760 x 284
-	YES1-0800GA4P	26	400	1.2	800	630	328 x 760 x 284
YES1-1000GA3P	YES1-1000GA4P	26	440	1.2	1000	800	328 x 760 x 363
YES1-1250GA3P	YES1-1250GA4P	50	440	1.2	1250	800	328 x 760 x 363
YES1-1600GA3P	YES1-1600GA4P	50	440	1.2	1600	1000	328 x 760 x 363
YES1-2000GA3P	YES1-2000GA4P	55	600	1.8	2000	2000	422 x 800 x 542
YES1-2500GA3P	YES1-2500GA4P	55	600	1.8	2500	2500	432 x 800 x 542
YES1-3200GA3P	YES1-3200GA4P	55	600	2.4	3200	3000	442 x 800 x 542

ACCESSORIES FOR YGL - YGLZ - YES1 SERIES



Code	Description
YU-1	Spare Handle for YES1-0040 to 0100 / YGLZ1-0125
YU-2	Spare Handle for YES1-0125 to 0160 / YGLZ1-0160 to 0630
YU-3	Spare Handle for YGL-0125 to 0630
YU-4	Spare Handle for YGL-800 to 3150 / YGLZ1-800 to 3150
YU-5	Spare Handle for YES1-0400 to 630A
YU-6	Spare Handle for YES1-800 to 3200A
YU-8	Spare Shaft for YGL-0125 to 0630 (360mm)
YU-9	Spare Shaft for YGL-0800 to 3150 / YGLZ1-0125 to 3150 (330mm)
YU-10	Face Plate On-Off (YGL)
YU-11	Face Plate On-Off-On (YGLZ1)
YU-12	Door Plate
YU-13	Extension Joint
YU-14	Joint Sleeve

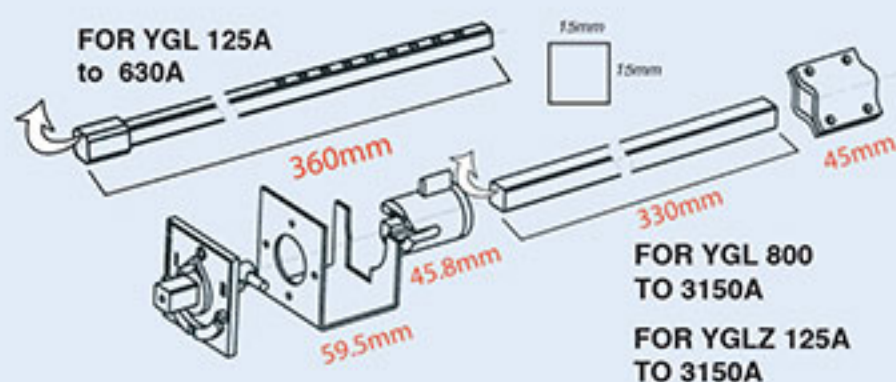

FOR YGL 800 TO 3150A
FOR YGLZ 125A TO 3150A

MOTORISED CHANGEOVER SWITCHES 63-250A

Rated Voltage: 690VAC@50Hz
All current ratings above 80A are AC23

Auxilliary contacts included.
No external bridging required.
Padlockable manual operating handle included.

Note: All 230 VAC units are supplied with one Power Supply.



40-63A

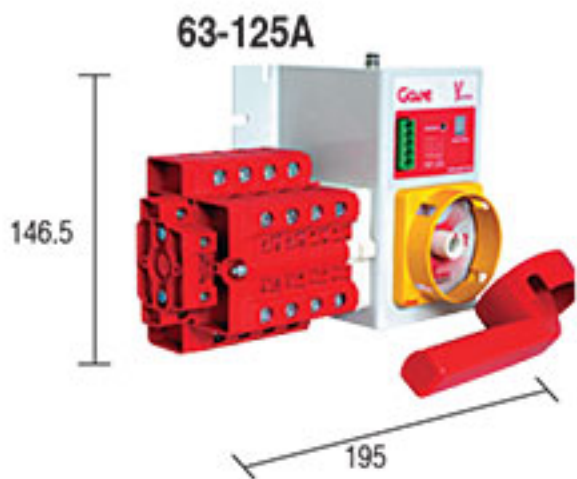

63-125A

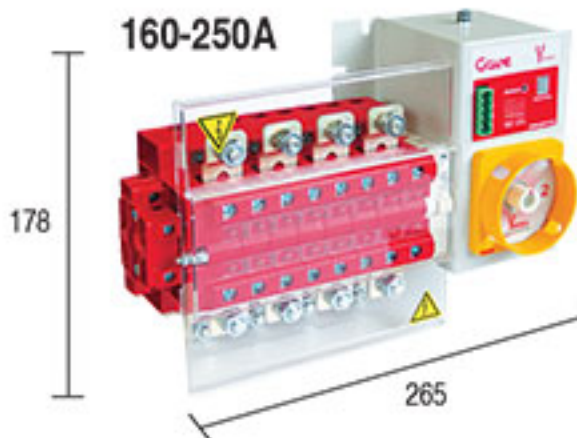

160-250A



New 3 Source motorised changeover switch is used in applications where three sources of supply are available, e.g:

- 0 = Off
- 1 = Mains
- 2 = Generator
- 3 = Battery Back-Up



Automatic Phase Selection to maintain power supply continuity for single phase loads. Especially useful in telecoms rectifier applications

4P Code	Rated Current	KVA @ 400V AC21	AC23 @ 400VAC	Terminal Capacity mm ²
Motor Volts 12VDC				
Y-5634101	40A (AC21)	28kVA	18.5kW	10 - 25mm ² Cage
Y-5635101	63A (AC22)	44kVA	-	10 - 25mm ² Cage
YL5636101	63A (AC23)	44kVA	37kW	16 - 50mm ² Cage
YL5638101	80A	55kVA	45kW	16 - 50mm ² Cage
YL5637101	100A	69kVA	45kW	16 - 50mm ² Cage
YL5639101	125A	87kVA	55kW	16 - 50mm ² Cage
YL563A101	160A	111kVA	60kW	70mm ² M8 Stud
YL563B101	200A	139kVA	75kW	95mm ² M8 Stud
YL563C101	250A	173kVA	90kW	120mm ² M8 Stud

4P Code	Rated Current	KVA @ 400V AC21	AC23 @ 400VAC	Terminal Capacity mm ²
Motor Volts 24VDC				
Y-5634201	40A (AC21)	28kVA	18.5kW	10 - 25mm ² Cage
Y-5635201	63A (AC22)	44kVA	-	10 - 25mm ² Cage
YL5636201	63A (AC23)	44kVA	37kW	16 - 50mm ² Cage
YL5638201	80A	55kVA	45kW	16 - 50mm ² Cage
YL5637201	100A	69kVA	45kW	16 - 50mm ² Cage
YL5639201	125A	87kVA	55kW	16 - 50mm ² Cage
YL563A201	160A	111kVA	60kW	70mm ² M8 Stud
YL563B201	200A	139kVA	75kW	95mm ² M8 Stud
YL563C201	250A	173kVA	90kW	120mm ² M8 Stud

4P Code	Rated Current	KVA @ 400V AC21	AC23 @ 400VAC	Terminal Capacity mm ²
Motor Volts 230VAC				
Y-5634301	40A (AC21)	28kVA	18.5kW	10 - 25mm ² Cage
Y-5635301	63A (AC22)	44kVA	-	10 - 25mm ² Cage
YL5636301	63A (AC23)	44kVA	37kW	16 - 50mm ² Cage
YL5638301	80A	55kVA	45kW	16 - 50mm ² Cage
YL5637301	100A	69kVA	45kW	16 - 50mm ² Cage
YL5639301	125A	87kVA	55kW	16 - 50mm ² Cage
YL563A301	160A	111kVA	60kW	70mm ² M8 Stud
YL563B301	200A	139kVA	75kW	95mm ² M8 Stud
YL563C301	250A	173kVA	90kW	120mm ² M8 Stud

4P Code	Rated Current	KVA @ 400V AC21	AC23 @ 400VAC	Terminal Capacity mm ²
3 Sources Motorised Changeover Switch 12VDC				
YL3936101	63A (AC23)	44kVA	37kW	10 - 25mm ² Cage
YL3938101	80A	55kVA	45kW	16 - 50mm ² Cage
YL3937101	100A	69kVA	45kW	16 - 50mm ² Cage
YL3939101	125A	87kVA	55kW	16 - 50mm ² Cage
YL393A101	160A	111kVA	60kW	70mm ² M8 Stud
YL393B101	200A	139kVA	75kW	95mm ² M8 Stud
YL393C101	250A	173kVA	90kW	120mm ² M8 Stud

4P Code	Rated Current	KVA @ 400V AC21	AC23 @ 400VAC	Terminal Capacity mm ²
3 Sources Motorised Changeover Switch 24VDC				
YL3936201	63A (AC23)	44kVA	37kW	10 - 25mm ² Cage
YL3938201	80A	55kVA	45kW	16 - 50mm ² Cage
YL3937201	100A	69kVA	45kW	16 - 50mm ² Cage
YL3939201	125A	87kVA	55kW	16 - 50mm ² Cage
YL393A201	160A	111kVA	60kW	70mm ² M8 Stud
YL393B201	200A	139kVA	75kW	95mm ² M8 Stud
YL393C201	250A	173kVA	90kW	120mm ² M8 Stud

4P Code	Rated Current	KVA @ 400V AC21	AC23 @ 400VAC	Terminal Capacity mm ²
Motorised R-O-S-T Phase selector Switch 12VDC				
YL6114101	40A (AC21)	28kVA	18.5kW	10 - 25mm ² Cage
YL6116101	63A (AC23)	44kVA	37kW	10 - 25mm ² Cage
YL6117101	100A	69kVA	45kW	16 - 50mm ² Cage
YL6119101	125A	87kVA	55kW	16 - 50mm ² Cage

Power Supply for above Change Over Switches				
Code	Output			Input
	DC Voltage	Rated Current	Rated Power	Voltage Range
	12V	2.5A	30	90~265VAC
	24V	2.5A	30	90~265VAC

MOTORISED INTERLOCKED MCCBS

Motorised, Electrical & Mechanically interlocked

- 80 - 800kVA
- Ideal for gensets
- One part number

TS



TERASAKI *Innovators in Protection Technology* **TemBreak**

Other combinations involving circuit breakers and isolators can be assembled to your order.

Each set comprises:
2 x 3-pole MCCBs
2 x Motor operators
2 x Aux interlocks

1 x Mechanical interlock set

Supplied in kit format

Workshop Assembly

Code		EEM125*	EEM250*	EEM400*	EEM630*	XSM800*	XSM1250*
Ratings:	Voltage Ue	525V	525V	690V	690V	690V	690V
	Current In	125A	250A	400A	600A	500-800A	630-1250A
	Gensets Icu 400/415	80kVA	160kVA	250kVA	400kVA	450-500kVA	550-850kVA
Overload Protection:		25kA	25kA	36kA	36kA	65kA	85kA
	Overload	0.63-1 x In	0.63 - 1 x In	0.63 - 1 x In	0.63 - 1 x In	Adj. 63-1 x In	Electronic
	Short Circuit	Adj. 6-12 x In	Adj. 6-12 x In	Adj.6-12 x In	Electronic	Adj. 5-10 x In	Electronic
Description	Qty						
Moulded Case MCCB	2	E125-NJ 125A	E250-NJ 250A	S400-CJ 400A	E630-NE 630A	S800-NJ 800A	S1250-SE 1250A
Motor Operator	2	MO755620	MO755729	MO756009	MO756009	MO735417	MO735363
Auxiliary Switch	2	A000317	A000317	A000317	A000317	A000317	A000317
RHS Mechanical Interlock	1	M033520	M033612	M033711	M033711	M036309	M036316
LHS Mechanical Interlock	1	M035005	M035104	M035265	M035265	M035302	M035319
Dimensions:	w	240	270	340	340	460	460
	h	155	165	260	260	273	370
	d	170	170	233	233	233	233
For accessories & further specs, see CB		E125	E250	S400	E630	S800	S1250

* Add Control Voltage for Motorised Operators :230VAC or 24VDC eg EEM400 230VAC

AUTO / MANUAL ATS

MCB Based Motorised Change Over Switch



Code	Rated Voltage	Current	Control Voltage	C/O Time (sec)	Poles	Size L x H x D
YEQ1-M1-25A/4P	400V	25A	230VAC	1.5 - 3	4	218 x 135 x 115
YEQ1-M1-40A/4P	400V	40A	230VAC	1.5 - 3	4	218 x 135 x 115
YEQ1-M1-63A/4P	400V	63A	230VAC	1.5 - 3	4	218 x 135 x 115

- Mechanical and electrical interlock
- Auto / Manual Operation
- LED indication
- Operating Life >10000 operations
- Overload Protected

AUTOMATIC TRANSFER SWITCHES IP54

Suitable for industrial, commercial and domestic 3ph+N 400V applications, the Automatic Transfer Switch panels provide automatic control between mains and standby generators. The controller monitors the mains supply and in the event of failure, provides a start signal to the generator and switches over to the generator supply when voltage and frequency have been stabilised. Return to the mains supply will be automatic after the mains supply has been restored.



- Motorised changeover switches can be manually operated and locked out for maintenance.
- Gave switch to terminals.YES1 direct connection to switch.
- Generator must be capable of remote start and stop
- Mains & Generator Voltage 400V 50Hz. Control voltage 12VDC with battery back up independent of generator battery voltage.
- **ATS-10** controller can be programmed to have additional delays and determine when to connect the generator to load by either monitoring the output voltage or responding to a signal from the generator.
- **IP65** with outer glazed door and instrument on inner door, manufactured to order.

Gave 4P	ATS 040	ATS 063	ATS 080	ATS 100	ATS 125	ATS 160	ATS 200	ATS 250	-	-	-	-
YES1 4P	ATS 040Y	ATS 063Y	ATS 080Y	ATS 100Y	-	ATS 160Y	-	ATS 250Y	ATS 400	ATS 630	ATS 1000	ATS 1250
YES1 3P	ATS 040Y3	ATS 063Y3	ATS 080Y3	ATS 100Y3	-	ATS 160Y3	-	ATS 250Y3	ATS 400-3	ATS 630-3	ATS 1000-3	ATS 1250-3
Rated Current	40A	63A	80A	100A	125A	160A	200A	250A	400A	630A	1000A	1250A
Generator	28kVA	44kVA	55kVA	69kVA	87kVA	111kVA	139kVA	173kVA	277kVA	436kVA	554kVA	865kVA
Size (mm)	600 x 400 x 260		700 x 500 x 260		800 x 600 x 260		1000 x 600 x 320		1200 x 800 x 320		1600 x 800 x 400	
Panel Colour	Orange (Red, Grey available on request)										Orange (Grey available on request)	

POLYCARBONATE ENCLOSED CHANGE OVER SWITCHES



TKM225UVV



KEM325VV

Polycarbonate Enclosed Change Over Switches IP66

2 & 3 Pole Code	No of Poles	4 Pole Code	AC21 @ 400/415/690V	AC22 @ 400/415/690V	AC23 @ 400/415V	AC23 KW @ 400/415V	AC23 KW @ 690V	Enclosure Size (mm) H x W x D
TKM225UVV	2P	-	25A	25A	25A	4kW	-	130 x 97 x 106
TKM240UVV	2P	-	40A	40A	40A	7.5kW	-	130 x 97 x 106
KEM325VV	3P	KEM425VV	40A	25A	25A	11kW	22kW	190 x 144 x 131
KEM340VV	3P	KEM440VV	63A	40A	40A	22kW	30kW	190 x 144 x 131
KEM363VV	3P	KEM463VV	80A	63A	40A	22kW	37kW	190 x 144 x 131
KEM380VV	3P	KEM480VV	100A	80A	63A	30kW	37kW	190 x 144 x 131
KEM3125VV	3P	KEM4125VV	160A	125A	100A	55kW	55kW	380 x 280 x 171
KEM3160VV	3P	KEM4160VV	200A	160A	135A	75kW	90kW	380 x 280 x 171

Features

- Self Extinguishing Material
- Padlockable Handle, accepts upto 3 padlocks
- Interlocked Handle
- IEC 60947-3
- Good UV Resistance



ENCLOSED CHANGE OVER SWITCHES



EVB Type



EVB-L Type

EVB Type - Enclosed Rotary Change Over Switches IP65

Amps AC21	Amps AC23	2-Pole 1-0-2	3-Pole 1-0-2	4-Pole 1-0-2	4P Size (mm) H x W x D
20A	15A	-	EVB1403	EVB1478	100 x 100 x 80
32A	25A	-	56SW332C/O	EVB1510	190 x 140 x 70
40A	32A	-	56SW340C/O	EVB1528	190 x 140 x 70
63A	44A	EVB1263*	56SW363C/O*	EVB1529*	240 x 190 x 90
75A	63A	-	EVB1429*	EVB1544*	240 x 190 x 90
100A	80A	-	EVB1003*	EVB1004*	240 x 190 x 130

*Add 'L' to code for LED Indication (White for Mains On, Blue for Generator run).



ESDC Type

ESDC Type - DB Type Changeover Switches IP65

Amps AC22A	2-Pole 1-0-2	3-Pole 1-0-2	4-Pole 1-0-2	Size (mm) H x W x D
63A	ESDC-2063	ESDC-3063	ESDC-4063	260 x 298 x 140
100A	ESDC-2100	ESDC-3100	ESDC-4100	260 x 298 x 140
120A	ESDC-2125	ESDC-3125	ESDC-4125	260 x 298 x 140



ESDCL Type

ESDCL Type - Enclosed Modular Change Over Switches IP65 - c/w pilot lights and buzzer

Amps AC22A	2-Pole 1-0-2	3-Pole 1-0-2	4-Pole 1-0-2	Size (mm) H x W x D
63A	ESDCL-2063	ESDCL-3063	ESDCL-4063	285 x 410 x 140
100A	ESDCL-2100	ESDCL-3100	ESDCL-4100	285 x 410 x 140
120A	ESDCL-2125	ESDCL-3125	ESDCL-4125	285 x 410 x 140

White LED for Mains On, Blue LED for Generator run, Buzzer on when main supply is restored and generator is still running.



ESDCTL Type

ESDCTL Type - Enclosed Change Over Switches IP65 - c/w pilot lights and buzzer

Amps AC21	Amps AC23	2-Pole 1-0-2	3-Pole 1-0-2	4-Pole 1-0-2	Size (mm) H x W x D
63A	40A	ESDCTL-2063	ESDCTL-3063	ESDCTL-4063	285 x 410 x 140
100A	80A	ESDCTL-2100	ESDCTL-3100	ESDCTL-4100	285 x 410 x 140
125A	80A	ESDCTL-2125	ESDCTL-3125	ESDCTL-4125	285 x 410 x 140

White for Mains On, Blue for Generator run.

NEW

ENCLOSED CHANGEOVER SWITCHES IP65

Rated Voltage: 690VAC
 Ratings below 63A are AC21
 Ratings from 62A-250A are AC23



16-32A



40-100A



100-125A



160-250A

Metal Enclosures c/w Gland Plate

Code 3P	AB562-16A	AB562-25A	AB562-32A	AB562-40A	AB562-63A	AB562P-100A	AB562-100A	AB562-125A	AB562-160A	AB562-200A	AB562-250A	
Code 4P	AB563-16A	AB563-25A	AB563-32A	AB563-40A	AB563-63A	AB563P-100A	AB563-100A	AB563-125A	AB563-160A	AB563-200A	AB563-250A	
Rated Current	16A	25A	32A	40A	63A	100A	100A	125A	160A	200A	250A	
Thermal Rating (Ithe)	20A	25A	40A	40A	70A	100A	100A	125A	160A	200A	250A	
Terminal Capacity	2.5-6 mm ²	2.5-6 mm ²	10-25mm ²	10-25mm ²	16-50mm ²	16-50mm ²	16-50mm ²	16-50mm ²	70mm ²	95mm ²	120mm ²	
Enclosure	Plastic						Steel - Grey RAL7032					
Size (mm) H x W x D	190 x 140 x 70			240 x 190 x 90	240 x 190 x 130		300 x 300 x 200		400 x 300 x 200	500 x 400 x 200	600 x 400 x 260	

CHANGE OVER SWITCHES



VB1232
Door Mount



VB1544
Door Mount



VG9906
Chassis Mount



CR0320006
22mm Door Mount

Change Over Switch Door Mount - 2 Pole

AC21 AC23A	16A 12A	32A 25A	40A 32A	63A 50A	75A 63A	115A 100A	200A 160A
2 Pole	-	-	VB1232	VB1263	-	-	-

Change Over Switch Door Mounting - 3 & 4 Pole

3 Pole	VB1353	VB1395	VB1403	VB1363	VB1429	VB1437	VB1445
4 Pole	VB1478	VB1510	VB1528	VB1463	VB1544	VB1551	VB1569
Plate Size (mm)	48 x 48	64 x 64	64 x 64	64 x 64	64 x 64	96 x 96	96 x 96

Change Over Switches Chassis Mount - 3 & 4 Pole

3 Pole	-	VG9906	ZL0496	-	ZL0505	VF2993	VF3058
4 Pole	-	ZL0538	ZL0546	-	VD9446	VF3033	VF3066
Plate Size (mm)	-	75 x 75	105 x 105	-	105 x 105	130 x 130	130 x 130

Change Over Switches 22mm Ø Door Mount

AC21 AC23A	16A 12A	32A 25A	40A 32A
2 Pole	CR0200006	CR0320006	CR0400006
3 Pole	CR0200007	CR0320007	CR0400007
4 Pole	CR0200039	CR0320039	CR0400039
Plate Size (mm)	48x48		

ROTARY ISOLATORS & CAM SWITCHES



Door Mounting Isolators (Switch supplied complete with operating handle)

AC21 AC23A	16A 12A	20A 16A	32A 25A	40A 32A	75A 63A	115A 100A
1 Pole	VB0728	VB0751	VB0769	VB0777	VB0793	-
2 Pole	VB0801	VB0835	VB0843	VB0850	VB0876	-
3 Pole	VB0884	VB0918	VB0926	VB0934	VB0959	VB0967
4 Pole	VB1056	VB1080	VB1018	VB1106	VB1122	VB1130
Plate Size (mm)	48x48	48x48	64x64	64x64	64x64	96x96

Isolator 22mm Ø Door Mount (48x48)

AC21 AC23	16A 12A	20A 16A	32A 25A	40A 32A
2 Pole	CR0160002	CR0200002	CR0320002	CR0400002
3 Pole	CR0160003	CR0200003	CR0320003	CR0400003
4 Pole	CR0160004	CR0200004	CR0320004	CR0400004

Isolator padlockable Front Door Mount (67x67)

AC21 AC23	16A 12A	20A 16A	32A 25A	40A 32A
3 Pole	CR01600G3	CR02000G3	CR03200G3	CR04000G3
4 Pole	CR01600G4	CR02000G4	CR03200G4	CR04000G4



Motor Control Switches - Door Mount

*For motors with capacitor

AC-1	AC23	1 Phase * Reversing	3 Phase Reversing	Star-delta	Plate Size (mm)
16A	12A	VB1940	VB1593	VB1841	48 x 48
20A	16A	-	VB1619	VB1866	48 x 48
32A	25A	-	VB1635	VB1882	64 x 64
40A	32A	-	VB1643	VB1890	96 x 96
50A	40A	-	VB1650	VB1908	96 x 96

Motor Control Switches - 22mm Door Mount

16A	12A	-	CR0160008	48 x 48
20A	16A	-	CR0200008	48 x 48
32A	25A	-	CR0320008	48 x 48
40A	32A	-	CR0400008	48 x 48

Stepping Switches Rear Door Mount

Description	AC21A	Code	Plate Marking	Size (mm)
1 Pole 3 step+ off	16A	VB3045	0-1-2-3	48 x 48
1 Pole 5 step+ off	16A	VG5325	0-1-2-1-4-5	48 x 48
1 Pole 7 step+ off	16A	VF3783	0-1-2-3-4-5-6-7	48 x 48



On - Off Switches 20Amps AC23 Switches spring return to centre

2 Poles	4 Poles	6 Poles
R201-23	R202-23	R203-23

Eschutcheon Plate

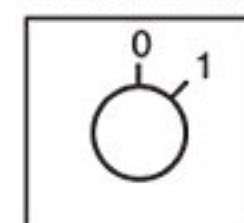

ROTARY ISOLATORS

Isolators

Rated Voltage: 690VAC.

c/w Operating handle and plate. All supplied as door mount. For other mounting options see accessories.



Simple 'click' front plate fixing.

IP20 finger safe.

Rated Current	ITH	AC21 @ 400VAC	AC23 @ 400VAC	1 Pole Code	Panel Depth	2 Pole Code	Panel Depth	3 Pole Code	Panel Depth	4 Pole Code	Panel Depth	Plate Size
12A	16A	7.5kW	4kW	AN500000	30.5mm	AN510000	30.5mm	AN520000	40.5mm	AN530000	40.5mm	48x48mm
16A	20A	11kW	5.5kW	AN501000	30.5mm	AN511000	30.5mm	AN521000	40.5mm	AN531000	40.5mm	
25A	32A	15kW	7.5kW	AN502000	30.5mm	AN512000	30.5mm	AN522000	40.5mm	AN532000	40.5mm	
32A	40A	18.5kW	11kW	AN503100	36.3mm	AN513100	36.3mm	AN523100	48.3mm	AN533100	48.3mm	60x60mm
40A	50A	22kW	18.5kW	AN504100	36.3mm	AN514100	36.3mm	AN524100	48.3mm	AN534100	48.3mm	
63A	70A	37kW	22kW	AN506100	46mm	AN516100	46mm	AN526100	62.5mm	AN536100	62.5mm	66x66mm
80A	100A	45kW	30kW	-	-	AN518100	46mm	AN528100	62.5mm	AN538100	62.5mm	
100A	100A	55kW	30kW	-	-	AN517100	46mm	AN527100	62.5mm	AN537100	62.5mm	
125A	125A	75kW	37kW	-	-	-	-	AN529100	62.5mm	AN539100	62.5mm	
160A	160A	90kW	52kW	-	-	-	-	AN52A100	95.5mm	AN53A100	95.5mm	
200A	200A	110kW	65kW	-	-	-	-	AN52B100	95.5mm	AN53B100	95.5mm	
250A	250A	132kW	-	-	-	-	-	AN52C100	95.5mm	AN53C100	95.5mm	

Spare Handles

for Isolators



Rated Current	Black Handle c/w Plate 0-1	White Handle c/w Plate 0-1	Padlockable	Padlockable	Padlockable (3 lock)	Padlockable (3 lock)
12-25A	AR0386040	AR0386010	AK1200143	AK1200523	AK1300143	AK1300523
32-40A	AR0386140	AR0386110	AK1200143	AK1200523	-	-
63-80A	AR0386640	AR0386610	AK1200146	AK1200526	-	-
100-250A	AR0386840	AR0386810	AK1200148	AK1200528	-	-

CHANGE OVER SWITCHES

Rated Voltage: 690VAC

c/w Operating handle and plate. All supplied as door mount. For other mounting options see accessories.

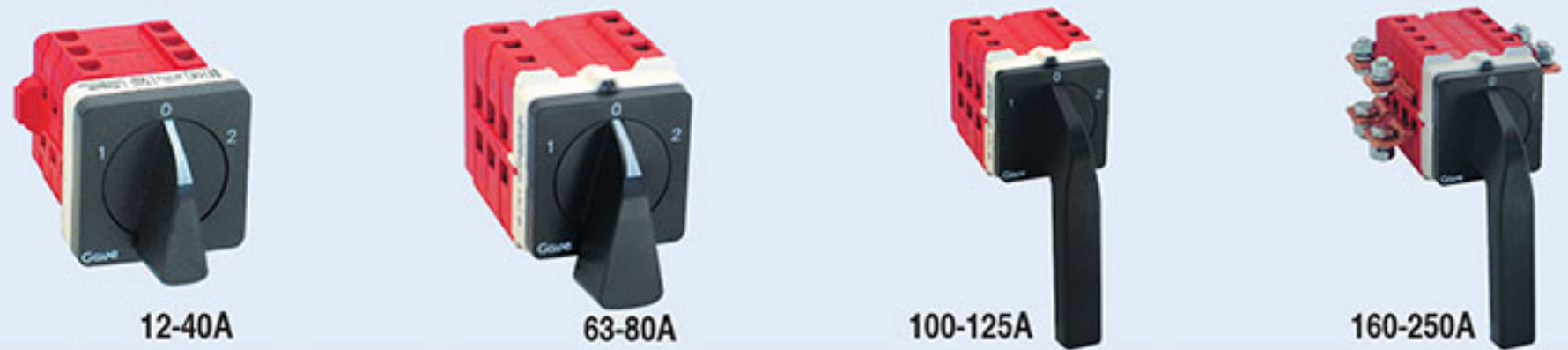

Rated Current	ITH	AC21 @ 400VAC	AC23 @ 400VAC	2 Pole Code	Panel Depth	3 Pole Code	Panel Depth	4 Pole Code	Panel Depth	Plate Size
16A	20A	11kW	5.5kW	-	-	AN5621000	50.5mm	AN5631000	60.5mm	48x48mm
25A	32A	15kW	7.5kW	-	-	AN5622000	50.5mm	AN5632000	60.5mm	
32A	40A	18.5kW	11kW	AN5613100	48.3mm	AN5623100	60.3mm	AN5633100	72.3mm	60x60mm
40A	50A	22kW	18.5kW	-	-	AN5624100	60.3mm	AN5634100	72.3mm	
63A	70A	37kW	22kW	AN5616100	62.5mm	AN5626100	79mm	AN5636100	95.5mm	66x66mm
80A	100A	45kW	30kW	-	-	AN5628100	79mm	AN5638100	95.5mm	
100A	100A	55kW	30kW	-	-	AN5627100	79mm	AN5637100	95.5mm	
125A	125A	75kW	37kW	-	-	AN5629100	79mm	AN5639100	95.5mm	
160A	160A	90kW	52kW	-	-	AN562A100	128.5mm	AN563A100	161.5mm	
200A	200A	110kW	65kW	-	-	AN562B100	128.5mm	AN563B100	161.5mm	
250A	250A	132kW	-	-	-	AN562C100	128.5mm	AN563C100	161.5mm	

MOTOR & PROCESS CONTROL CAM SWITCHES

Motor Control Switches

Door Mount

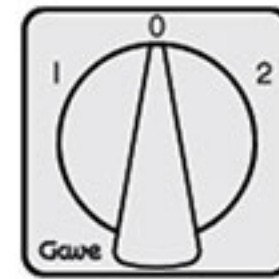
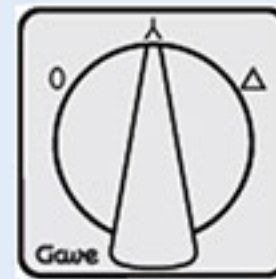
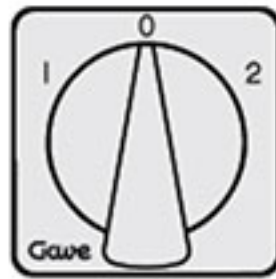
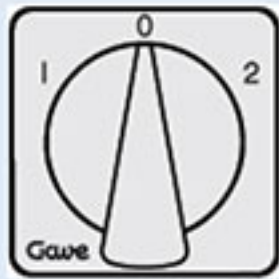

Rated Current	AC21 @ 400VAC	AC23 @ 400VAC	DC Reversing	Panel Depth	3 Phase Reversing	Panel Depth	Star Delta	Panel Depth	Dahlander	Panel Depth	Plate Size
12A	7.5kW	4kW	AN6700000	40.5mm	AN6710000	50.5mm	AN6400000	60.5mm	AN6810000	60.5mm	48x48mm
16A	11kW	5.5kW	-	-	AN6711000	50.5mm	AN6401000	60.5mm	AN6811000	60.5mm	48x48mm
25A	15kW	7.5kW	-	-	AN6712000	50.5mm	AN6402000	60.5mm	AN6812000	60.5mm	48x48mm
32A	18.5kW	10kW	-	-	AN6713100	60.3mm	AN6403100	72.3mm	AN6813100	72.3mm	64x64mm
40A	22kW	11kW	-	-	AN6714100	60.3mm	AN6404100	72.3mm	AN6814100	72.3mm	64x64mm

Stepping Switches - Door Mount



Type	Rated Current	AC23 @ 400VAC	Code	Plate Marking	Panel Depth	Plate Size
1 Pole 3 step + off	12A	4kW	AN6110000	0-1-2-3	40.5mm	48x48mm
1 Pole 5 step + off	12A	4kW	AN6130000	0-1-2-3-4-5	50.5mm	48x48mm
1 Pole 7 step + off	12A	4kW	AN6150000	0-1-2-3-4-5-6-7	60.5mm	48x48mm

Overlapping Change Over Switch

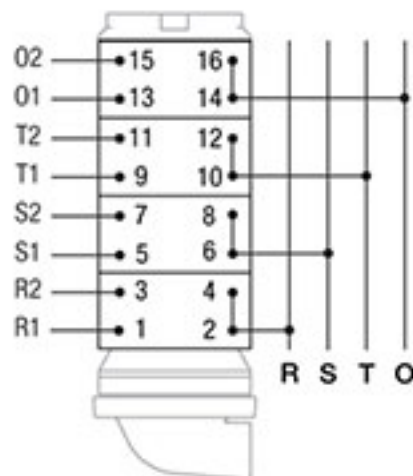

By-Pass Change Over Switch

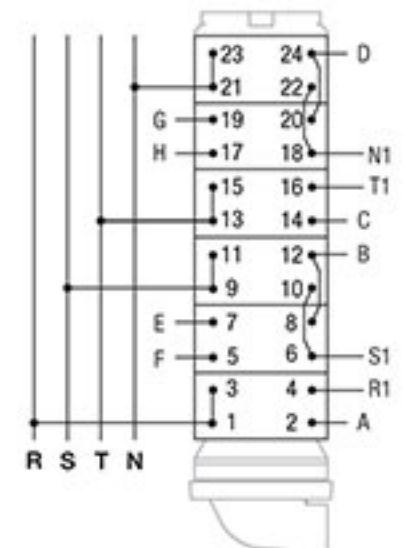

Rated Current	AC21 @ 400VAC	AC23 @ 400VAC	4 Pole Code	Panel Depth	Rated Current	AC21 @ 400VAC	AC23 @ 400VAC	4 Pole Code	Panel Depth
12A	7.5kW	4kW	AN5430000	60.5mm	25A	15kW	7.5kW	AN9842000	80.5mm
16A	11kW	5.5kW	AN5431000	60.5mm	40A	22kW	18.5kW	AN9844100	96.3mm
25A	15kW	7.5kW	AN5432000	60.5mm	63A	37kW	22kW	AN9846100	128.5mm
32A	18.5kW	11kW	AN5433100	72.3mm	80A	45kW	30kW	AN9848100	128.5mm
40A	22kW	18.5kW	AN5434100	72.3mm	100A	55kW	30kW	AN9847100	128.5mm
63A	37kW	22Kw	AN5436100	95.5mm	125A	75kW	37Kw	AN9849100	128.5mm

Mounting Accessories - for all Gawe Cam Switches



Code	Description	For Switch Amps
AK0000003	Base mounting plate	Up to 40A
AK0000006	Base mounting plate	63-250A
AK0100007	Din rail mounting plate	Up to 63A
AK1730003	Base mounting kit with extension shaft and door interlock	Up to 40A
AK1730006	Base mounting kit with extension shaft and door interlock	63-250A
AK1740003	Din rail mounting kit with extension shaft and door interlock	Up to 40A
AK1740006	Din rail mounting kit with extension shaft and door interlock	63-250A
AK2240003	IP65 gasket for door mount switches	Up to 40A
AK2240006	IP65 gasket for door mount switches	63-250A

ILLUMINATED CAM SWITCHES

Padlockable Illuminated Isolators - Position controlled

Red in Off Position, Green in On Position.
Supply for LED: 230VAC*



Illuminated Changeover Switches - Position controlled

Red in Position 0, Green in Position 1 and 2.
Supply for LED: 230VAC*



On/Off Multi-coloured Illuminated Switches - Illumination controlled by external signal

Green/ Red/ Yellow illumination.
Supply for LED: 230VAC*



Isolators

Rated Current	ITH	AC21 @ 400VAC	AC23 @ 400VAC	2 Pole Code	Panel Depth	3 Pole Code	Panel Depth	4 Pole Code	Panel Depth	Plate Size
16A	20A	11kW	5.5kW	AB551112L	66mm	AB552112L	76mm	AB553112L	76mm	48x48mm
32A	40A	18.5kW	11kW	AB551312L	77mm	AB552312L	89mm	AB553312L	89mm	64x64mm
40A	50A	22kW	18.5kW	AB551412L	77mm	AB552412L	89mm	AB553412L	89mm	
63A	70A	37kW	22kW	AB551612L	87mm	AB551612L	103mm	AB553712L	103mm	
100A	100A	55kW	30kW	AB551712L	87mm	AB552712L	103mm	AB553712L	103mm	
125A	125A	75kW	37kW	AB551912L	87mm	AB552912L	103mm	AB553912L	103mm	

* Other Colours and Supply voltages Available on request

Changeover Switches

Rated Current	ITH	AC21 @ 400VAC	AC23 @ 400VAC	2 Pole Code	Panel Depth	3 Pole Code	Panel Depth	4 Pole Code	Panel Depth	Plate Size
16A	20A	11kW	5.5kW	A-561112L	76mm	A-562312L	86mm	A-563312L	96mm	48x48mm
32A	40A	18.5kW	11kW	A-561312L	89mm	A-562312L	101mm	A-563312L	113mm	64x64mm
40A	50A	22kW	18.5kW	A-561412L	89mm	A-562412L	101mm	A-563412L	113mm	
63A	70A	37kW	22kW	A-561612L	103mm	A-562612L	120mm	A-563612L	136mm	
100A	100A	55kW	30kW	A-561712L	103mm	A-562712L	120mm	A-563712L	136mm	
125A	125A	75kW	37kW	A-561912L	103mm	A-562912L	120mm	A-563912L	136mm	

* Other Colours and Supply voltages Available on request

Multi-Coloured Switches

Rated Current	ITH	AC21 @ 400VAC	AC23 @ 400VAC	2 Pole Code	Panel Depth	3 Pole Code	Panel Depth	4 Pole Code	Panel Depth	Plate Size
16A	20A	11kW	5.5kW	A-5511T0S	74mm	A-5521T0S	84mm	A-5531T0S	84mm	48x48mm
32A	40A	18.5kW	11kW	-	-	A-5523T0S	89mm	A-5533T0S	89mm	64x64mm
40A	50A	22kW	18.5kW	-	-	A-5524T0S	89mm	A-5534T0S	89mm	
63A	70A	37kW	22kW	-	-	A-5526T0S	103mm	A-5536T0S	103mm	
100A	100A	55kW	30kW	-	-	A-5527T0S	103mm	A-5537T0S	103mm	
125A	125A	75kW	37kW	-	-	A-5529T0S	103mm	A-5539T0S	103mm	

* Other Colours and Supply voltages Available on request

Add on Lighting Modules for Gawe CAM Switches

Type		12-16A Code	32-125A Code
Position Controlled 0 = Red, 1 = Green	230V	AK2400123F	AK2400126F
	400V	AK2440123F	AK2440126F
	24V	AK2420123F	AK2420126F
Position Controlled 0 = Red, 1&2 = Green	230V	AK2402123F	AK2402126F
	400V	AK2442123F	AK2442126F
	24V	AK2422123F	AK2422126F
External Signal Control Yellow, Red, Green	230V	AK2503123F	AK2503126F
	400V	AK2543123F	AK2543126F
	24V	AK2523123F	AK2523126F
Padlockable Handle for Isolators		AK1230503	AK1230506

For compatible switches see page 230-231



Position Controlled

External Signal Controlled

Padlockable Handle



TECHNICAL INFORMATION

Utilization Categories IEC 947-4-1

A.C. Contactors/Relays

Category	Description & Application
AC-1	Non-Inductive/Slightly Inductive Loads - Heaters, Resistance Furnaces etc.
AC-2	Slip Ring Motors (Start/Stop/Reverse) - Wire Drawing, Stone Crushing
AC-3	Squirrel Cage Motors (Start/Stop/Reverse) - Compressors, Mixers, Conveyors
AC-4	Squirrel Cage Motors (Plugging & Inching) -Cranes, Hoists
AC5a	Switching of Electrical Discharge Lamps - Mercury Lamp, Sodium Vapour Lamp
AC5b	Switching of Incandescent Lamps - Tungsten Filament Lamp
AC6a	Switching of Transformers - Switching of LT Transformer with Load (contactor on transformer primary)
AC6b	Switching of Capacitor Banks - Switching of Capacitor Bank for PF Correction
AC7a	Slightly Inductive Load in Household Appliances and Similar Applications - Switching of Fans, Mixers, Blenders etc.
AC7b	Motor Load for Household Application - Washing Machine, Dish Washer, etc.
AC8a	Hermetic Refrigerant Compressor Motor Control with Manual Resetting of Overloads - Refrigeration
AC8b	Hermetic Refrigerant Compressor Motor Control with Automatic Resetting of Overloads - Window Air Conditioners

A.C. Switches/Isolators

Category	Description & Application
AC-12	Control of Resistive Loads and Solid State Loads with Isolation by Opto Couplers
AC-13	Control of Solid State Loads with Transformer Isolation
AC-14	Control of Small Electromagnetic Loads ($\leq 72VA$)
AC-15	Control of Electromagnetic Loads ($>72VA$)
AC-20	Connecting and disconnecting under no-load conditions
AC-21	Switching of resistive loads including moderate overloads
AC-22	Switching of mixed resistive and inductive loads including moderate overloads
AC-23	Switching of motor loads or other highly inductive loads

D.C. Contactors/Relays

Category	Description & Application
DC-1	Non-Inductive/Slightly Inductive Loads - Heaters, Resistance Furnaces
DC-3	Shunt Motors (Starting, Plugging & Inching) Dynamic breaking of DC Motors - Shunt Motors, Textile Ind., Steel Ind.
DC-5	Series Motor (Starting, Plugging & Inching) Dynamic Breaking of DC Motors - Series Motor Used in EMU's, Lifts, Hoists
DC-6	Incandescent Lamps - Light used In Railways Coaches

D.C. Switches/Isolators

Category	Description & Application
DC-12	Control of Resistive Loads and Solid State Loads with Isolation by Opto Couplers
DC-13	Control of DC Electromagnets
DC-14	Control of Electromagnetic Loads Having Economy Resistors in Circuit
DC-20	Connecting and disconnecting under no-load conditions
DC-21	Switching of resistive loads including moderate overloads
DC-22	Switching of mixed resistive and inductive loads including moderate overloads
DC-23	Switching of motor loads or other highly inductive loads

IP Rating for Enclosures – IEC 529

FIRST CHARACTERISTIC NUMERAL: Protection against ingress of solid foreign objects and against access to dangerous parts							
Meaning	0	1	2	3	4	5	6
Protection against ingress of:	No Protection	Solid objects larger than $\varnothing 50mm$	Solid objects larger than $\varnothing 12,5mm$	Solid objects larger than $\varnothing 2,5mm$	Solid objects larger than $\varnothing 1mm$	Dust in a harmful quantity	Dust (total protection)
Personal protection against access with:	No Protection	Back of hand	Finger	Tool		Wire	

SECOND CHARACTERISTIC NUMERAL: Protection against water										
Meaning	0	1	2	3	4	5	6	7	8	9
Protection against effect of:	No Protection	Vertically falling drops of water	Vertically falling drops of water with maximum inclination of 15°	Rain	Splashing water	Water jet	Powerful water jet	Temporary immersion	Continuous immersion	Powerful hot water jet

Example

Protection against ingress of dust in a harmful quantity

IP 5 4

Protected against effects of splashing water

Standard F.L.C. data for 4 Pole motors

Rated Power		Standard 3-Phase 4 pole motors Line Connected				Phase Connected (Star-Delta)*		Single Phase Motors
kW	Hp	380V A	400V A	550V A	1000V A	380V A	400V A	230V A
0.37	0.5	1	1	0.72	0.4	-	-	3.4
0.55	0.75	1.6	1.5	1.16	0.64	-	-	4.6
0.75	1	2	1.9	1.4	0.75	-	-	5.8
1.1	1.5	2.6	2.5	1.9	1	-	-	8.4
1.5	2	3.5	3.3	2.5	1.3	-	-	11.2
2.2	3	5	4.7	3.6	1.9	-	-	16.4
3	4	6.6	6.3	4.8	2.5	-	-	21
4	5.5	8.5	8.1	6.2	3.3	4.9	4.7	28
5.5	7.5	11.5	10.9	8.6	4.5	6.7	6.3	37
7.5	10	15.5	14.7	11.5	6	9	8.5	-
10	13.5	20	19	14.3	7.5	11.6	11	-
11	15	22	21	16	8.7	12.8	12	-
15	20	30	28.5	22	12	17.4	16.6	-
18.5	25	37	35	27	14.3	21	20	-
22	30	44	42	32	17	25	24	-
30	40	60	57	43	23	35	33	-
37	50	72.5	69	53	28	42	40	-
45	60	85	81	62	33	49	47	-
55	75	105	100	76	40	64	61	-
75	100	138	131	100	53	79	75	-
90	125	170	161	123	65	99	94	-
110	150	205	195	152	78	119	113	-
132	175	245	233	179	91	142	135	-
160	220	300	285	218	117	174	165	-
200	270	370	351	268	149	215	204	-
220	300	408	388	296	161	237	225	-
250	350	475	451	344	200	275	262	-
315	430	584	555	422	240	339	322	-
355	480	636	604	477	265	369	350	-
375	500	670	636	503	278	389	369	-
425	580	760	722	548	303	441	419	-

* These are the values of F.L.C. as seen by the overload and main/delta contactors when phase connected within a Star-Delta starter.

Note: Always check the rating plate of the motor when commissioning *before* switching on.

Cable ratings

3 & 4 Core copper PVC/SWA/PVC 600/1000V cables - SABS 1507/1990

Cable Size (mm ²)	Electrical Properties				Gland Size Type ACG		
	Current Ratings			Volt Drop (mV/A/m)	3 Core	4 Core	5 Core
	Ground A	Ducts A	Air A				
1.5	23	18	18	25.080	0	0	0
2.5	30	24	24	15.363	0	0/1	2
4	38	31	32	9.561	1	1	2
6	48	39	40	6.391	1	2	3
10	64	52	54	3.793	2	2	
16	82	67	72	2.390	2	2/3	
25	126	101	113	1.515	3	3	
35	147	120	136	1.097	3	3/4	
50	176	144	167	0.817	4	4	
70	215	175	207	0.576	4	4/5	
95	257	210	253	0.427	4/5	5	
120	292	239	293	0.348	5	5/6	
150	328	369	336	0.294	5	6	
185	369	303	384	0.250	6	6	
240	422	348	447	0.211	6	7	
300	472	397	509	0.189	6/7	7	

Borehole pump motor F.L.C. data

100mm submersible motors

kW	F.L.C.	
	230V Amps	400V Amps
0.25	3.1	-
0.37	3.9	1.3
0.56	5.0	1.6
0.75	6.0	2.2
1.12	8.8	3.0
1.50	11.8	3.9
2.20	17.0	5.9
3	-	7.2
4	-	9.3
5.5	-	13.2

Note:

Always check the rating plate of the motor when commissioning *before* switching on. Borehole pumps and motors require specialised protection. For a wide range of protection devices as well as special borehole control panels, see pages 40 and 41.

400V STAR-DELTA STARTERS – COMPONENT SELECTION GUIDE

Motor	F.L.C. 4 Pole	Main/Delta Contactors	Star Contactor	Overload Relay FLC x 3	Ammeter	CT	Back Up		Isolator	DIN MCB (D Curve)	MCCB Std kA
							BS Fuse	DIN Fuse			
7.5kW	14.7A	TC1-D09	TC1-D09	TR2-D09314 8.5A	SQ72-20AD	(Direct)	TIA25 24700-25A		CSSD25D3	GW92467 (6kA)	E160-SF 25A (16kA)
11kW	21A	TC1-D12	TC1-D09	TR2-D12316 12A	SQ72-25AD	(Direct)	TIA32 24700-32A		CSSD40D3	GW92469 (6kA)	E160-SF 32A (16kA)
15kW	28.5A	TC1-D18	TC1-D12	TR2-D18321 16.5A	SQ72-30AD	(Direct)	TIS40 24700-40A		CSSD63D3	GW92470 (6kA)	E160-SF 40A (16kA)
18.5kW	35A	TC1-D25	TC1-D25	TR2-D25322 20A	SQ72-40AD	(Direct)	TIS50 24700-50A		CSSD63D3	GW92471 (6kA)	E160-SF 50A (15kA)
22kW	42A	TC1-D32	TC1-D25	TR2-D32353 24A	SQ72-50AD	(Direct)	TIS63 24700-63A		CSSD63D3	GW93386 (16kA)	E160-SF 63A (16kA)
30kW	57A	TC1-D38	TC1-D32	TR2-D32355 33A	SQ72-5 + SQ72SP 60/5A	DS-605	TIS63M80 24700-80A		CSSD125D3	GW93386 (16kA)	E160-SF 80A (16kA)
37kW	69A	TC1-D40	TC1-D40	TR2-D65357 40A	SQ72-5 + SQ72SP 75/5A	DS-755	TIS80 24700-80A		CSSD125D3	GW93387 (16kA)	E160-SF 100A (16kA)
45kW	81A	TC1-D50	TC1-D40	TR2-D65357 47A	SQ72-5 + SQ72SP 100/5A	DS-1005	TCP100 24585-100A		CSSD125DM3	GW93388 (16kA)	E160-SF 125A (16kA)
55kW	100A	TC1-D65	TC1-D50	TR2-D65359 58A	SQ72-5 + SQ72SP 125/5A	DS-1255	TCP125 24585-125A		CSSD160DM3	-	E160-SF 160A (16kA)
75kW	131A	TC1-D80	TC1-D80	TR2-D80363 76A	SQ72-5 + SQ72SP 150/5A	DS-1505	TCP160 24585-160A		CSSD160DM3	-	E250-SCF 175A (16kA)
90kW	161A	TC1-D95	TC1-D80	TR2-D95365 93A	SQ72-5 + SQ72SP 200/5A	DS1-2005	TF200 24720-200A		CSSD200DM3	-	E250-SCF 200A (16kA)
110kW	195A	LC1-FDP115A	LC1-FDP115A	LR1-F160 113A	SQ72-5 + SQ72SP 250/5A	DS1-2505	TKF250 24720-250A		CSSD250DM3	-	E250-SCF 250A (16kA)
132kW	233A	LC1-FDP150A	LC1-FDP115A	LR1-F160 135A	SQ72-5 + SQ72SP 250/5A	DS1-2505	TKF250 24720-250A		CSSD250DM3	-	E400-NS 400A (25kA)
160kW	285A	LC1-FDP185A	LC1-FDP185A	LR1-F200 165A	SQ72-5 + SQ72SP 300/5A	DS1-3005	TKF315 24582-315A		CSSD315DM3	-	E400-NS 400A (25kA)
200kW	351A	LC1-FDP225A	LC1-FDP185A	LR1-F250 203A	SQ72-5 + SQ72SP 400/5A	DS2-4005	TM400 24582-400A		CSSD400D3	-	E630-NE 630A (36kA)
250kW	451A	LC1-FDP265A	LC1-FDP265A	LR1-F315 260A	SQ72-5 + SQ72SP 500/5A	DS2-5005	TTM500 24588-500A		CSSD630K3	-	E630-NE 630A (36kA)
315kW	555A	LC1-FDP330A	LC1-FDP330A	LR1-F400 320A	SQ72-5 + SQ72SP 600/5A	DS2-6005	TTM630 24588-630A		CSSD630K3	-	-
375kW	636A	LC1-FDP400A	LC1-FDP400A	LR1-F400 367A	SQ72-5 + SQ72SP 750/5A	DS2-7505	-		CSSD800K3	-	-

Notes: 1) The above guide excludes material such as enclosure, mechanical interlock, electrical interlocks and timer. 2) The F range contactors have been selected for use with horizontal mechanical interlocks. If vertical mechanical interlocks are used, the star point contactor can be reduced in size. 3) The above guide is not applicable to Star-Delta reversing starters.

4) Fuse & circuit breaker selection assumes that starting time does not exceed 20 secs.

TYPE 2 CO-ORDINATION CHART

Type "2" coordination according to IEC947-4-1 / IS13947-4-1

- Short-circuit current $I_q = 50kA$, Voltage : 400/ 415V, 50/60Hz
- DOL Feeders

Standard Motors AC-3 AT 400/415V 1500RPM		Manual Motor Start			Contactor	
		MPCB Code	Thermal Overload Release Setting Range	Magnetic Release Response Current		
KW	Amps				Code	Amps
		TCMS-32H 0.16	0.1 - 0.16	2.08	TC1-M06	6
0.06	0.2	TCMS-32H 0.25	0.16 - 0.25	3.25	TC1-M06	6
0.09	0.3	TCMS-32H 0.4	0.25-0.4	5.2	TC1-M06	6
0.12	0.4	TCMS-32H 0.63	0.4 - 0.63	8.19	TC1-M06	6
0.18	0.6	TCMS-32H 0.63	0.4 - 0.63	8.19	TC1-M06	6
0.25	0.8	TCMS-32H 1	0.63 - 1	13	TC1-M06	6
0.37	1.1	TCMS-32H 1.6	1 - 1.6	20.8	TC1-M06	6
0.55	1.5	TCMS-32H 1.6	1 - 1.6	20.8	TC1-M06	6
0.75	1.9	TCMS-32H 2.5	1.6 - 2.5	32.5	TC1-M12	12
1.1	2.7	TCMS-32H 4	2.5 - 4	52	TC1-M16	16
1.5	3.6	TCMS-32H 4	2.5 - 4	52	TC1-M16	16
2.2	5.2	TCMS-32H 6	4 - 6	78	TC1-M16	16
3	6.8	TCMS-32H 8	5 - 8	104	TC1-M16	16
4	9	TCMS-32H 10	6 - 10	130	TC1-M16	16
5.5	11.5	TCMS-32H 13	9 - 13	169	TC1-M16	16
7.5	15.5	TCMS-32H 17	11 - 17	221	TC1-M16	16
10	20	TCMS-32H 22	14 - 22	286	TC1-D25	25
11	22	TCMS-32H 26	18 - 26	338	TC1-D25	25
15	29	TCMS-32H 32	22 - 32	416	TC1-D32	32
18.5	35	TCMS-63H 40	28 - 40	520	TC1-D50	50
22	41	TCMS-63H 50	34 - 50	650	TC1-D50	50
30	55	TCMS-63H 63	45 - 63	819	TC1-D65	65
37	67	TCMS-100H 75	55 - 75	975	TC1-D80	80
-	-	TCMS-100H 90	70 - 90	1170	TC1-D95	95
45	80	TCMS-100H 100	80 - 100	1300	TC1-D95	95

Definition type '2' coordination according to IEC 947-4-1

- The contactor or the starter must not endanger persons or system in the event of a short-circuit
- The contactor or the starter must be suitable for further use.
- No damage to the overload relay or other parts may occur with the exception of welding of the contactor or starter contacts provided that these can be easily separated without significant deformation (such as with a screwdriver)

Thermal Release Trip Current

The adjustable inverse bimetal trip reliably protects motors against overloads. The curve shows the mean operating current at an ambient temperature of 20°C starting from cold. Careful testing and setting ensures effective motor protection even in the case of single-phasing.

Magnetic Release Trip Current

The instantaneous magnetic trip has a fixed operating current setting. This corresponds to 13 times the maximum value of the setting range, at a lower setting it is correspondingly higher.

Current setting I_e

The overload trip corresponds to a thermal overload relay in a motor starter conforming to IEC 947-4-1. If a different value is prescribed (e.g. reduced I_e for cooling medium having a temperature higher than 40°C or a place of installation higher than 200m above sea level), the setting current is equal to the reduced rated current I_e of the motor.

TCMS-32AF Tripping Curve

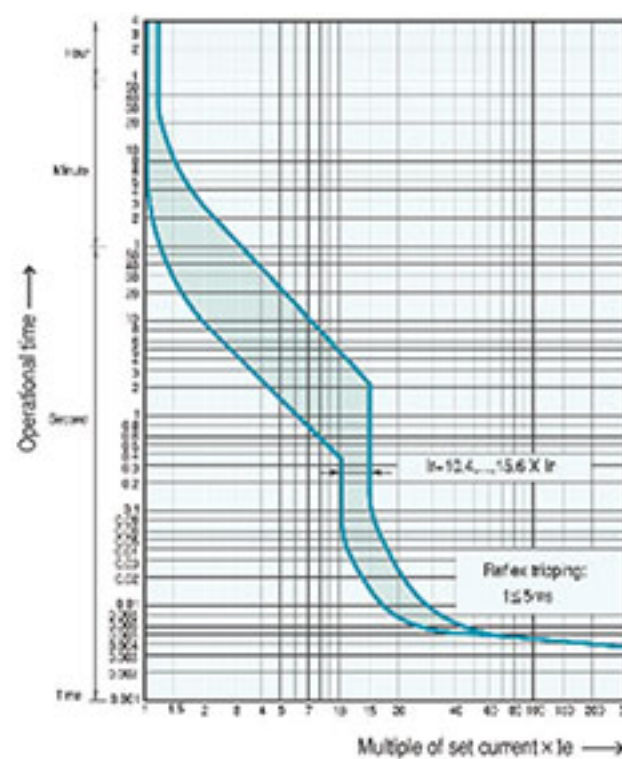

TCMS-63, 100AF Tripping Curve

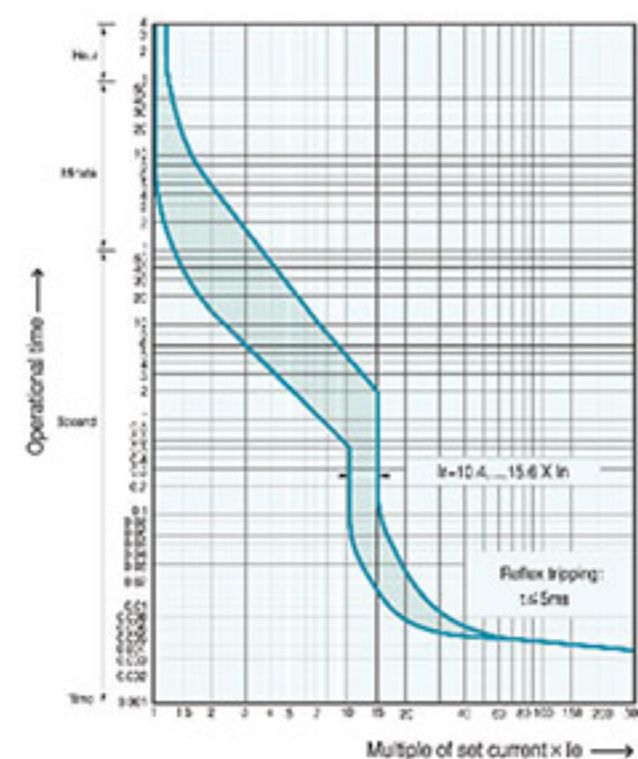

SELECTION CHART FOR TYPE -2 COORDINATION WITH MPCB : DOL FEEDERS

Sr. No.	Motor Rating, 3Ph, 415 V			Motor Protection Circuit Breaker				Contactor	
	KW	HP	I FL(A)	Type	Thermal O/L Release Range (A)	Relay Reference	Magnetic Release Resonse Current	Type	Rating (A) Min
1	0.06	0.08	0.2	TCMS-32S-0.25A	0.16-0.25	TR2-D09302	3.25	TC1-D09	9
2	0.09	0.125	0.3	TCMS-32S-0.4A	0.25-0.4	TR2-D09303	5.2	TC1-D09	9
3	0.12	0.165	0.4	TCMS-32S-0.63A	0.4-0.63	TR2-D09304	8.19	TC1-D09	9
4	0.18	0.25	0.6	TCMS-32S-0.63A	0.4-0.63	TR2-D09304	8.19	TC1-D09	9
5	0.25	0.35	0.8	TCMS-32S-1A	0.63-1	TR2-D09305	13	TC1-D09	9
6	0.37	0.5	1.1	TCMS-32S-1.6A	1-1.6	TR2-D09306	20.8	TC1-D09	9
7	0.55	0.75	1.5	TCMS-32S-1.6A	1-1.6	TR2-D09306	20.8	TC1-D09	9
8	0.75	1	1.9	TCMS-32S2.5A	1.6-2.5	TR2-D09307	32.5	TC1-D18	18
9	1.1	1.5	2.7	TCMS-32S4A	2.5-4.0	TR2-D09308	52	TC1-D18	18
10	1.5	2	3.6	TCMS-32S4A	2.5-4.0	TR2-D09308	52	TC1-D18	18
11	2.2	3	5.2	TCMS-32S6A	4.0-6.0	TR2-D09310	78	TC1-D18	18
12	3	4	6.8	TCMS-32S8A	5.0-8.0	TR2-D09312	104	TC1-D18	18
13	4	5.5	9	TCMS-32S10A	6.0-10.0	TR2-D09314	130	TC1-D18	18
14	5.5	7.5	11.5	TCMS-32H13A	9.0-13.0	TR2-D12316	169	TC1-D18	18
15	7.5	10	15.5	TCMS-32H17A	11.0-17.0	TR2-D18321	221	TC1-D25	25
16	10	13.5	20	TCMS-32H22A	14-22	TR2-D25322	286	TC1-D25	25
17	11	15	22	TCMS-32H26A	18-26	TR2-D25322	338	TC1-D32	32
18	15	20	29	TCMS-32H32A	22-32	TR2-D32353	416	TC1-D40	40
19	18.5	25	35	TCMS-63H40A	28-40	TR2-D40355	520	TC1-D40	40
20	22	30	41	TCMS-63H50A	34-50	TR2-D65357	650	TC1-D50	50
21	30	40	55	TCMS-63H63A	45-63	TR2-D65357	819	TC1-D65	65
22	37	50	67	TCMS-100H75A	55-75	TR2-D65359	975	TC1-D80	80
23	40	54	72	TCMS-100H90A	70-90	TR2-D80363	1170	TC1-D95	95
24	45	60	80	TCMS-100H100A	80-100	TR2-D95365	1300	TC1-D95	95

Note :- (1) Type - 2, Co-ordination Chart as per IS 13947-4 / IEC 60947-4, Suitable for 3- Phase Motor 415V, 50/60 Hz AC, Iq = 50kA

(2) Type 2 Co-ordination recommendation with C&S Make MPCB rating upto 100A / + Contactors

(3) Product Selection is for normal starting conditions of Electric Motor with starting time < 6seconds.

(4) The above 30KW will be used with external C T

SELECTION CHART FOR TYPE -2 COORDINATION WITH MPCB: STAR DELTA FEEDERS

Sr. No.	Motor Rating, 3Ph, 415V			Motor Protection Circuit Breaker			Contactor Line / Delta		Contactor Star			
	KW	HP	I FL(A)	I PH(A)	Type	A	Thermal O/L Release Range (A)	Magnetic Release Response Current (A)	Type	Rating (A)	Type	Rating (A)
1	3	4	6.8	3.7	TCMS-32S4A	4	2.5-4	52	TC1-D18	9	TC1-D09	9
2	4	5.5	9	5.2	TCMS-32S6A	6	4-6	78	TC1-D18	12	TC1-D09	9
3	5.5	7.5	11.5	6.5	TCMS-32S8A	8	5-8	104	TC1-D18	18	TC1-D09	12
4	7.5	10	15.5	9.2	TCMS-32S10A	10	6-10	130	TC1-D18	18	TC1-D09	12
5	10	13.5	20	11.0	TCMS-32H13A	13	9-13	169	TC1-D18	25	TC1-D09	18
6	11	15	22	12.0	TCMS-32H17A	17	11-17	221	TC1-D25	25	TC1-D12	18
7	15	20	29	16.2	TCMS-32H22A	22	14-22	286	TC1-D25	25	TC1-D18	18
8	18.5	25	35	19.7	TCMS-32H26A	26	18-26	338	TC1-D40	40	TC1-D32	32
9	22	30	41	23.2	TCMS-32H32A	32	22-32	416	TC1-D40	50	TC1-D32	40
10	30	40	55	30.6	TCMS-63H40A	40	28-40	520	TC1-D40	65	TC1-D32	50
11	37	50	67	37.5	TCMS-63H50A	50	34-50	650	TC1-D50	80	TC1-D32	65
12	45	60	80	45.0	TCMS-63H50A	50	34-50	650	TC1-D50	80	TC1-D32	65
13	55	75	97	55.4	TCMS-63H63A	63	45-63	819	TC1-D65	95	TC1-D32	80
14	75	100	132	75.6	TCMS-100H90A	90	70-90	1170	TC1-D95	150	TC1-D63	115
15	90	125	160	90.1	TCMS-100H100A	100	80-100	1300	TC1-D95	185	TC1-D63	150

Note :- (1) Type - 2, Co-ordination Chart as per IS 13947-4 / IEC 60947-4, Suitable for 3- Phase Motor 415V, 50/60 Hz AC, Iq = 50kA

(2) Type 2 Co-ordination recommendation with C&S Make MPCB rating upto 100A / + Contactors + EMPR

(3) Product Selection is for normal starting conditions of Electric Motor with starting time < 6seconds.

(4) The above 30KW will be used with external C T

(5) MPCB will be used only in the main circuit not in the phase circuit



SELECTION CHART : FUSE PROTECTED STAR DELTA FEEDERS TYPE'2' CO-ORDINATION Iq=50k A@ 380V, 415V& 440V 3-Ø 50Hz AS PER IEC60947-4-1 & IS/IEC 60947-4-1																	
MOTORS RATING 380V			MOTORS RATING 415V			MOTORS RATING 440V			SWITCH FUSE TYPE *	FUSE LINK REFERENCE CODE (gG)	FUSE LINK TYPE		CONTACTOR			BIMETAL OVERLOAD RELAY	
											gG (A)	aM (A)	Main	Delta	Star	Type	Rating (A)
P(kW)	I Line	I ph	P(kW)	I Line	I ph	P(kW)	I Line	I ph									
1.5	3.7	2.14	1.5	3.5	2.02	1.5	3.1	1.79	CDFL0010	10	4	TC1-D09	TC1-D09	TC1D09	TR2-D09307	1.6-2.5	
2.2	5	2.89	2.2	4.8	2.77	2.2	4.5	2.60	CDFL0010	10	4	TC1-D09	TC1-D09	TC1D09	TR2-D09308	2.5-4	
3	6.6	3.81	3	6.5	3.75	3	5.8	3.35	CDFL0016	16	4	TC1-D09	TC1-D09	TC1D09	TR2-D09308	2.5-4	
4	8.5	4.91	4	8.2	4.73	4	7.9	4.56	CDFL0016	16	6	TC1-D09	TC1-D09	TC1D09	TR2-D09310	4-6	
5.5	11.5	6.64	5.5	11	6.35	5.5	10.4	6.00	CDFL0020	20	8	TC1-D09	TC1-D09	TC1D09	TR2-D09312	5.5-8	
7.5	15.5	8.95	7.5	14	8.08	7.5	13.7	7.91	CDFL0020	20	10	TC1-D09	TC1-D09	TC1D09	TR2-D09314	7-10	
11	22	12.70	11	21	12.12	11	20.1	11.61	CDFL0032	32	12	TC1-D12	TC1-D12	TC1D12	TR2-D12316	9-13	
15	30	17.32	15	28	16.17	15	26.5	15.30	CDFL0035	35	16	TC1-D18	TC1-D18	TC1D18	TR2-D18321	12-18	
18.5	37	21.36	22	40	23.09	22	39	22.52	CDFL01 50	50	20	TC1-D25	TC1-D25	TC1D25	TR2-D25322	17-25	
22	44	25.40	25	47	27.14	30	51.5	29.73	CDFL01 50	50	25	TC1-D32	TC1-D32	TC1D32	TR2-D32353	23-32	
30	59	34.06	30	55	31.76				CDFL01 63	63	32	TC1-D40	TC1-D40	TC1D40	TR2-D40355	30-40	
37	72	41.57	37	66	38.11	37	64	36.95	CDFL01 80	80	40	TC1-D40	TC1-D40	TC1D40	TR2-D65357	37-50	
45	85	49.08	45	80	46.19	45	76	43.88	CDFL01 80	80	50	TC1-D50	TC1-D50	TC1D50	TR2-D65357	37-50	
55	105	60.62							CDFL01 100	100	63	TC1-D80	TC1-D80	TC1D80	TR2-D65359	48-65	
75	140	80.83	75	135	77.94	75	124	71.59	CDFL01 125	125	80	TC1-D80	TC1-D80	TC1D80	TR2D80363	63-80	
90	170	98.15	90	160	92.38	90	156	90.07	CDFL01 125	125	80	TC1-D95	TC1-D95	TC1D95	TR2-D95365	80-93	
110	210	121.25	110	200	115.47	110	180	103.93	CDFL01 160	160	100	LC1-FDP115A	LC1-FDP115A	LC1FDP115A	LR1-F105	65-105	
132	250	144.34	132	230	132.79	132	215	124.13	CDFL1 200	200	125	LC1-FDP150A	LC1-FDP150A	LC1FDP150A	LR1-F125	80-125	
160	300	173.21	160	270	155.89	160	256	147.81	CDFL1 250	250	160	LC1-FDP150A	LC1-FDP150A	LC1FDP150A	LR1-F100	100-160	
200	380	219.40	220	380	219.40	220	360	207.85	CDFL1 250	250	200	LC1-FDP185A	LC1-FDP185A	LC1FDP185A	LR1-F200	125-200	
220	420	242.49	250	430	248.27	250	401	231.52	CDFL1 250	250	200	LC1-FDP265A	LC1-FDP265A	LC1FDP265A	LR1-F250	160-250	
250	480	277.14							CDFL2 315	315	250	LC1-FDP265A	LC1-FDP265A	LC1FDP265A	LR1-F250	160-250	
300	570	329.10	300	510	294.46	300	480	277.14	CDFL2 400	400	315	LC1-FDP330A	LC1-FDP330A	LC1FDP330A	LR1-F315	200-315	
			335	580	334.87	335	540	311.78	CDFL2 400	400	315	LC1-FDP400A	LC1-FDP400A	LC1FDP400A	LR1-F400	250-400	
						375	590	340.65	CDFL2 400	400	315	LC1-FDP400A	LC1-FDP400A	LC1FDP400A	LR1-F400	250-400	

* For Neutral, N will be added (CSSDF32D3N). For 4 pole 3 will be replaced by 4 (CSSDF32D4)

SELECTION CHART FOR TYPE -2 COORDINATION WITH MCCB : DOL FEEDERS (IEC60947-4-1)

Sr. No.	Motor Rating, 3Ph, 380/415 V			Motor Protection Circuit Breaker		Contactor		Thermal Overload Relay
	KW	HP	I FL(A)	MCCB		Type	Rating (A)	Setting range (A)
				Type	Rating IR (A)			
1	0.37	0.5	1.03	CS100NMTU12A3P	12	TC1-D09	9	1-1.6
2	0.55	0.75	1.6	CS100NMTU12A3P	12	TC1-D09	9	1-1.6
3	0.75	1	2	CS100NMTU12A3P	12	TC1-D09	9	1.6-2.5
4	1.1	1.5	2.6	CS100NMTU12A3P	12	TC1-D32	32	2.5-4
5	1.5	2	3.5	CS100NMTU12A3P	12	TC1-D32	32	2.5-4
6	2.2	3	5	CS100NMTU12A3P	12	TC1-D40	40	4-6
7	3	4	6.6	CS100NMTU12A3P	12	TC1-D40	40	5.5-8
8	3.7	5	7.7	CS100NMTU12A3P	12	TC1-D40	40	7-10
9	4	5.5	8.5	CS100NMTU12A3P	12	TC1-D40	40	7-10
10	5.5	7.5	11.5	CS100NMTU20A3P	20	TC1-D40	40	9-13
11	7.5	10	15.5	CS100NMTU20A3P	20	TC1-D40	40	12-18
12	9	12	18.5	CS100NMTU20A3P	20	TC1-D40	40	14-22
13	10	13.5	20	CS100NMTU20A3P	20	TC1-D40	40	14-22
14	11	15	22	CS100NMTU32A3P	32	TC1-D40	40	14-22
15	15	20	30	CS100NMTU32A3P	32	TC1-D80	80	23-32
16	18.5	25	37	CS100NMTU50A3P	50	TC1-D80	80	30-40
17	22	30	44	CS100NMTU50A3P	50	TC1-D80	80	37-50
18	25	33.5	52	CS100NMTU63A3P	63	TC1-D80	80	48-65
19	30	40	60	CS100NMTU63A3P	63	TC1-D80	80	55-70
20	33	44	68	CS100NMTU100A3P	100	TC1-D80	80	55-70
21	37	50	72	CS100NMTU100A3P	100	TC1-D80	80	55-70
22	40	54	79	CS100NMTU100A3P	100	LC1-FDP115A	115	55-70
23	45	60	85	CS100NMTU100A3P	100	LC1-FDP115A	115	80-93
24	50	77	90	CS100NMTU100A3P	100	LC1-FDP115A	115	80-93
25	55	75	97	CS160NMTU160A3P	160	LC1-FDP115A	115	65-105
26	75	100.5	135	CS160NMTU160A3P	160	LC1-FDP150A	150	100-160
27	90	121	160	CS250MTU220A3P	220	LC1-FDP185A	185	125-200
28	110	148	200	CS250MTU220A3P	220	LC1-FDP225A	225	125-200
29	132	177	230	CS400NMTU320A3P	320	LC1-FDP265A	265	200-315
30	160	215	270	CS400NMTU320A3P	320	LC1-FDP400A	330	200-315
31	200	268	361	CS630NMTU500A3P	500	LC1-FDP400A	400	250-400
32	220	295	380	CS630NMTU500A3P	500	LC1-FDP630A	500	250-400
33	250	335	430	CS630NMTU500A3P	500	LC1-FDP630A	500	315-500

Note :- (1) Type - 2, Co-ordination Chart as per IS 13947-4 / IEC 60947-4, Suitable for 3- Phase Motor 415V, 50/60 Hz AC, Iq = 50kA

(2) Type 2 Co-ordination recommendation with C&S Make Winbreak2 MCCB rating + Contactors

(3) Product Selection is for normal starting conditions of Electric Motor with starting time < 6seconds.

(4) The above 30KW will be used with external C T

SELECTION CHART FOR TYPE -2 COORDINATION 50 KA WITH HRC FUSES - DOL FEEDERS

Standard Motor Rating, 415V AC		SDF		HRC Fuse gG max		Contactor (min)		Bimetal Overload Relay	
KW	HP	I FL(A)	Type	Rating (A)	Type	Rating (A)	Type	Type	Rating (A)
0.06	0.08	0.2	CSSDF32D3	32	CDFL00	2	TC1D-09	TR2-D09303	0.25-0.4
0.09	0.13	0.3	CSSDF32D3	32	CDFL00	2	TC1D-09	TR2-D09303	0.25-0.4
0.12	0.17	0.4	CSSDF32D3	32	CDFL00	2	TC1D-09	TR2-D09304	0.4-0.63
0.18	0.25	0.6	CSSDF32D3	32	CDFL00	2	TC1D-09	TRD-D09304	0.4-0.63
0.25	0.33	0.8	CSSDF32D3	32	CDFL00	4	TC1D-09	TR2-D09304	0.63- 1.0
0.37	0.5	1.1	CSSDF32D3	32	CDFL00	4	TC1-D09	TR2-D09305	0.63-1.0
0.55	0.75	1.5	CSSDF32D3	32	CDFL00	4	TC1-D09	TR2-D09306	1.0-1.6
0.75	1	1.9	CSSDF32D3	32	CDFL00	6	TC1-D09	TR2-D09307	1.6-2.5
1.1	1.5	2.7	CSSDF32D3	32	CDFL00	10	TC1-D09	TR2-D09308	2.5-4.0
1.5	2	3.6	CSSDF32D3	32	CDFL00	10	TC1-D09	TR2-D09308	2.5-4.0
2.2	3	5.2	CSSDF32D3	32	CDFL00	16	TC1-D09	TR2-D09310	4.0-6.0
3.7	5	7.2	CSSDF32D3	32	CDFL00	20	TC1-D12	TR2-D09312	5.0-8.0
4	5.5	9	CSSDF32D3	32	CDFL00	20	TC1-D12	TR2-D09314	7.0-10.0
5.5	7.5	11.5	CSSDF32D3	32	CDFL00	25	TC1-D18	TR2-D09316	9.0-13.0
7.5	10	15.5	CSSDF63D3	63	CDFL00	32/35	TC1-D18	TR2-D18321	12.0-18.0
9	12	18	CSSDF63D3	63	CDFL00	32/35	TC1-D18	TR2-D18321	12.0-18.0
11	15	22	CSSDF63D3	63	CDFL1 00	50	TC1-D25	TR2-25322	17-25
15	20	29	CSSDF63D3	63	CDFL1 00	63	TC1-D32	TR2-D32353	23-32
18.5	25	35	CSSDF63D3	63	CDFL1 00	63	TC1-D40	TR2-D40355	28-36
22	30	41	CSSDF125D3	125	CDFL1 00	80	TC1-D50	TR2-D40355	30-40
25	35	45	CSSDF125D3	125	CDFL1 00	100	TC1-D65	TR2-D65357	37-50
30	40	55	CSSDF125D3	125	CDFL1 00	100	TC1-D80	TR2-D35359	48-65
37	50	67	CSSDF125D3	125	CDFL1 00	125	TC1-D95	TR2-D65361	55-70
45	60	80	CSSDF160D3	160	CDFL1 00	160	LC1-F115	LR1-F(M)105	65-105
55	75	100	CSSDF200D3	200	CDFL-1	160	LC1-F115	LR1-F(M)105	65-105
60	80	105	CSSDF200D3	200	CDFL-1	200	LC1-F150	LR1-F(M)125	80-125
80	110	140	CSSDF250D3	250	CDFL-1	250	LC1-F150	LR1-F160	100-160
90	125	160	CSSDF315D3	315	CDFL-2	315	LC1F-185	LR1-F200	125-200
100	136	170	CSSDF315D3	315	CDFL-2	315	LC1-F185	LR1-F200	125-200
132	175	230	CSSDF400D3	400	CDFL-2	315	LC1-F265	LR1-F250	160-250
150	200	250	CSSDF400D3	400	CDFL-2	400	LC1-F265	LR1-F250	160-250
160	220	270	CSSDF400D3	400	CDFL-2	500	LC1-F330	LR1-F315	200-315
200	270	340	CSSDF630D3	630	CDFL-3	630	LC1-F400	LR1-F500	315-500
257	350	425	CSSDF630D3	630	CDFL-3	630	LC1-F500	LR1-F500	315-500

Note :- (1) Type - 2, Co-ordination Chart as per IS 13947-4 / IEC 60947-4, Suitable for 3- Phase Motor 50 Hz, 415V AC, Iq = 50kA

(2) Type 2 Co-ordination recommendation with C&S Make HRC Fuse Type BS & DIN as applicable

(3) In the event the recommended combination is changed to accommodate another brand / rating of SDF/ Fuses / Contactor/ OLR, it shall be the responsibility of the person making such a change to assure type 2 performance

(4) Product Selection is for normal starting conditions of Electric Motor with starting time < 6seconds.

(5) Product Selection is based on operational temperature upto +550 C. Thus at 600C service temperature the Overload Relay has to be derated. Example - The overload relay with setting 7~10A at 600C can be used upto 9.4A only.

WITH MORE THAN
85,000
ELECTRICAL PRODUCTS

YOUR OPTIONS
ARE ENDLESS

ACDC
DYNAMICS

ACDC
DYNAMICS

ACDC
DYNAMICS

ACDC
DYNAMICS

ACDC
DYNAMICS

AC/DC SFC TC



5th Edition September 2018

DISTRIBUTED BY:

Specifications are subject to change from time to time,
without notification in this publication

© ACDC Dynamics CC 2018

HEAD OFFICE - JOHANNESBURG

P.O. Box 3812, Edenvale,
1610, South Africa
26 Nguni Drive
Longmeadow Estate West
Edenvale, Gauteng
South Africa

info@acdc.co.za

Reception 010 202 3300

Sales 010 202 3400

Technical 010 202 3500

Fax 010 202 3365

www.acdc.co.za

BRANCH CONTACT DETAILS

Johannesburg 010 202 3300

Germiston 011 418 9600

Cape Town 021 510 0710

Pinetown 031 700 4215

Riverhorse 031 492 4800

www.acdc.co.za

Distributors & Franchises throughout Southern Africa

© ACDC Dynamics CC 2018

THINK ELECTRICAL